

SQFlex

Renewable-energy-based water supply systems

50/60 Hz



be
think
innovate

GRUNDFOS 

1. Product data	4
Performance range	4
Applications	5
SQFlex system	5
Type keys	7
Pumped liquids	7
Curve conditions	7
System overview	8
2. Features and benefits	9
Dry-running protection	9
High efficiency	9
Overvoltage and undervoltage protection	9
Overload protection	9
Overtemperature protection	10
Maximum Power Point Tracking (MPPT)	10
Wide voltage range	10
Reliability	10
Installation	10
Service	10
3. Applications	11
SQFlex Solar	11
SQFlex Solar with CU 200 and level switch	12
SQFlex Solar with backup generator	13
SQFlex Solar with CU 200 and backup generator	14
SQFlex Solar with backup batteries	15
SQFlex Wind	16
SQFlex Wind with CU 200 and level switch	17
SQFlex Combi	18
SQFlex Combi with CU 200 and level switch	19
SQFlex system with generator as power supply	20
4. System components	21
SQF submersible pump	21
CU 200 SQFlex control unit	21
CIU 273 SQFlex GRM control unit	23
IO 50 SQFlex switch box	24
IO 101 SQFlex switch box	24
IO 102 SQFlex breaker box	25
Charge controller	25
Wind turbine	25
Generator	25
5. System sizing	26
Sizing of SQFlex system	26
6. Performance curves	27
SQF 0.6-2	27
SQF 0.6-3	27
SQF 1-8	28
SQF 1.2-2	28
SQF 1.2-3	29
SQF 2.5-2	29
SQF 3A-10	30
SQF 5A-3	30
SQF 5A-7	31
SQF 7-4	31
SQF 9-3	32
SQF 14-3	32
7. Technical data	34
Dimensions and weights	34
Electrical data	34
SQF pump	35

CU 200 SQFlex control unit	35
CIU 273 SQFlex GRM control unit	36
IO 50 SQFlex switch box	36
IO 101 SQFlex switch box	36
IO 102 SQFlex breaker box	37
Charge controller	37
Material specification, helical rotor pump	38
Material specification (SQF 1)	39
Material specification (SQF 3A, SQF 5A)	40
Material specification (SQF 7, SQF 9, SQF 14)	41
Material specification, motor	42
8. Product numbers	43
SQF submersible pump	43
CU 200 SQFlex control unit	43
CIU 273 SQFlex GRM control unit	43
IO 50 SQFlex switch box	43
IO 101 SQFlex switch box	43
IO 102 SQFlex breaker box	43
Charge controller	43
Submersible drop cables	43
9. Accessories	44
Flow sleeve for SQFlex 3" standard version (EN 1.4301/AISI 304)	44
Flow sleeve for SQFlex 4" standard version (EN 1.4301/AISI 304)	44
Grease	45
Level switch	45
Pressure switch	45
Submersible drop cable	45
Cable termination kit, type KM	45
Cable clips	45
Straining wire	46
Wire clamp	46
Zinc anodes	46
Solar cables	46
10. Grundfos Product Center	47

1. Product data

Performance range

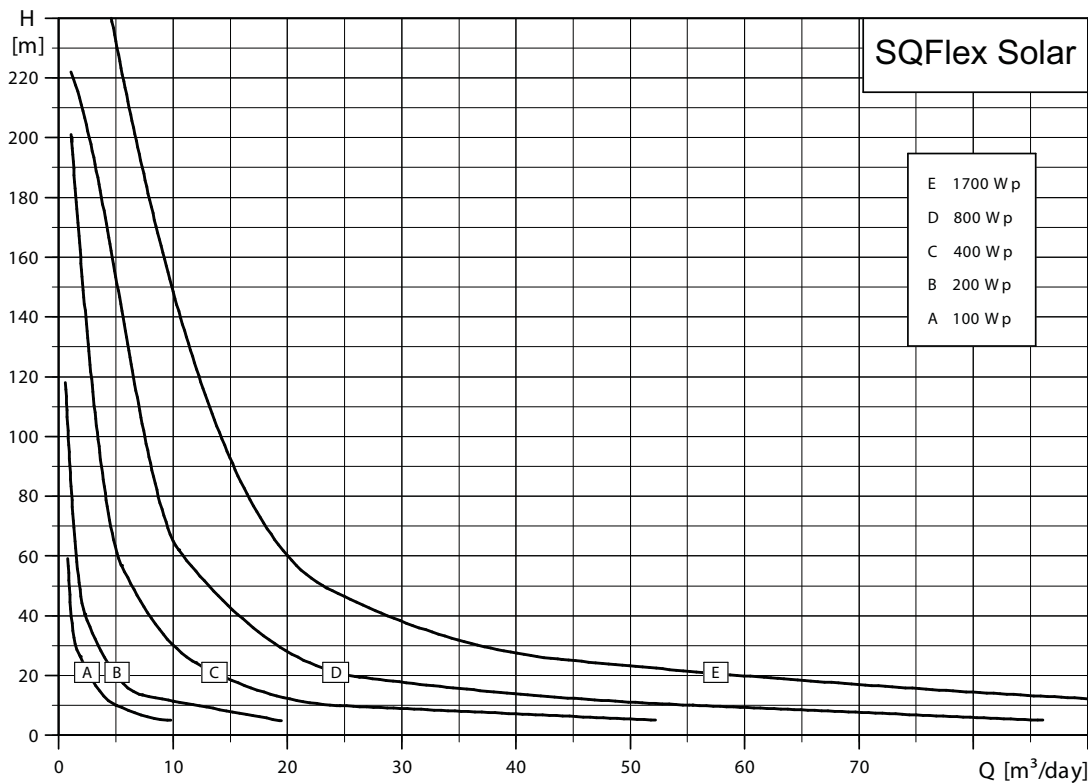

TM02 2337 2309

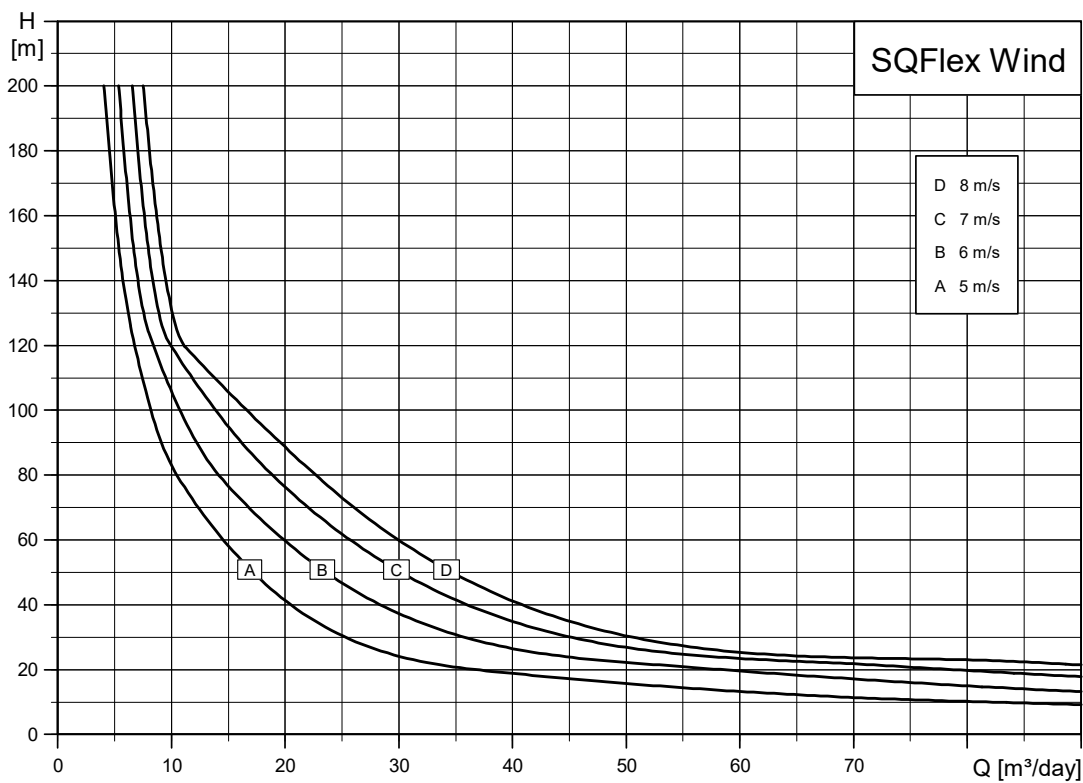

TM02 2411 2309

Note: The curves must not be used as guarantee curves.

Applications

Being designed for continuous as well as intermittent operation, the SQFlex system is especially suitable for water supply applications in remote locations, such as:

- villages, schools, hospitals, single-family houses, etc.
- farms
 - watering of cattle
 - irrigation of fields and greenhouses
- game parks and game farms
 - watering applications
- conservation areas
 - pumping of surface water
- floating pump installations for pumping of water from ponds and lakes.

SQFlex system

The SQFlex system is a reliable water supply system based on renewable energy sources, such as solar and wind energy. The SQFlex system incorporates an SQF submersible pump.

Very flexible as to its energy supply and performance, the SQFlex system can be combined and adapted to any need according to the conditions on the installation site.

The system components are:

- SQF submersible pump
- CU 200 SQFlex control unit
- CIU 273 SQFlex GRM control unit
- IO 50 SQFlex switch box
- IO 101 SQFlex switch box
- IO 102 SQFlex breaker box
- charge controller
- energy supply system:
 - solar panels
 - wind turbine
 - generator
 - batteries.

Pump

The SQF pump range comprises two pump technologies:

- helical rotor pump (3") for high heads and small flow rates
- centrifugal pump (3") for low heads and small flow rate; centrifugal pump (4") for low heads and large flow rates.

The performance curves below illustrate the pump performance of the two pump models.

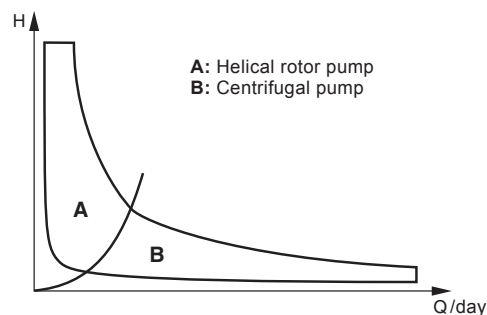

TM02 2425 3901

Fig. 1 Performance ranges for helical rotor and centrifugal pumps

All pump types are available in two material variants:

- SQF is the standard version made of stainless steel DIN W.-Nr. 1.4301
- SQF-N is made of stainless steel DIN W.-Nr. 1.4401.

Motor

The motor has been developed specifically for the SQFlex system and is designed according to the permanent-magnet principle with built-in electronic unit.

The SQFlex 3" motor range comprises only one motor size, the MSF 3 with a maximum power input (P1) of 300 W or 1400 W.

The motor speed range is 3000-10,700 min⁻¹ or 500-3600 min⁻¹, depending on the motor size, power input and load.

The motor is available in two material variants:

- MSF 3 is the standard version made of stainless steel DIN W.-Nr. 1.4301.
- MSF 3 N is made of stainless steel DIN W.-Nr. 1.4401.

The motor has three internal limitations:

- maximum power input (P1) of 300 W or 1400 W
- maximum current of 8.4 A
- maximum speed of 10,700 min⁻¹ or 3600 min⁻¹.

The pump delivers its maximum performance when one of the above limitations is reached.

Supply voltage

Flexible as regards power supply and power range, the motor can be supplied with either DC or AC voltage:

- 30-300 VDC, PE
- 1 x 90-240 V - 10 %/+ 6 %, 50/60 Hz, PE.

CU 200 SQFlex control unit

CU 200 is a combined status and control unit for the SQFlex system. Moreover, CU 200 enables connection of a level switch placed in a water reservoir or tank.

CIU 273 SQFlex GRM control unit

The CIU 273 SQFlex is designed to work directly with the SQFlex pump and enables monitoring the system operation anywhere in the world through Grundfos Remote Monitoring. Moreover, CIU 273 enables connection of a start/stop switch, level switch and pulsating water meter.

IO 50 SQFlex switch box

The IO 50 is an on/off switch box designed for switching the system power supply on and off.

IO 101 SQFlex switch box

The IO 101 is an on/off switch box designed for switching the system power supply on and off.

The IO 101 is used in solar-powered SQFlex systems with a backup generator.

IO 102 SQFlex breaker box

The IO 102 is an on/off breaker box designed for switching the system power supply on and off.

The IO 102 is used in wind-powered SQFlex systems or wind- and solar-powered SQFlex systems.

The IO 102 makes it possible to slow down or stop the wind turbine.

Charge controller

The charge controller is used when a battery backup system is installed with an SQFlex pumping system.

Solar modules

Grundfos' solar modules have been developed specifically for the SQFlex system. The solar modules are equipped with plugs and sockets enabling easy connection in parallel.

The number of solar modules required depends on these factors:

- quantity of water required
- head required
- installation location.

For further information on solar modules, please contact your local Grundfos company.

Generator

In case the power supply from its primary source of energy is temporarily insufficient, the SQFlex system can be powered by a diesel- or petrol-driven generator.

Batteries

The SQFlex system can be powered by batteries with a voltage supply of 30-300 VDC and a maximum current of 8.4 A. DC power supply operation will be limited to the highest possible power depending on the voltage. For example 48 VDC will give a limiting maximum power of 403 W.

Type keys

Helical rotor pumps

Example	SQF	1.2	-2	x
Type range				
Rated flow rate [m ³ /h] at 3000 min ⁻¹				
Number of stages				
Blank = Stainless steel DIN W.-Nr. 1.4301				
N = Stainless steel DIN W.-Nr. 1.4401				

Centrifugal pumps

Example	SQF	5A	-3	x
Type range				
Rated flow rate [m ³ /h] and pump generation				
Number of stages				
Blank = Stainless steel DIN W.-Nr. 1.4301				
N = Stainless steel DIN W.-Nr. 1.4401				

Pumped liquids

SQF pumps are applicable in thin, clean, non-aggressive, non-explosive liquids, not containing solid or long-fibred particles larger than sand grains.

pH value: 5 to 9.

Liquid temperature: 0 °C to +40 °C.

The pump can run at free convection (~ 0 m/s) at maximum +40 °C.

Sand content

Maximum sand content: 50 g/m³.

A higher sand content will reduce the pump life considerably due to wear.

Salt content

The table below shows the resistance of stainless steel to Cl⁻. The values in the table are based on a pumped liquid with a pH value of 5 to 9.

Stainless steel DIN W.-Nr.	Cl ⁻ content [ppm]	Liquid temperature [°C]
1.4301	0-300	< 40
	300-500	< 30
1.4401	0-500	< 40

For additional protection, for instance if the Cl⁻ content exceeds 500 ppm, zinc anodes can be used. See section [Zinc anodes](#) on page 46.

Curve conditions

Performance range, SQFlex Solar

The SQFlex Solar performance range on page 4 is based on these data:

- solar radiation on a tilted surface (tilt angle of 20 °)
- H_T = 6 kWh/m² per day
- ambient temperature: +30 °C
- 20 ° northern latitude.

Performance range, SQFlex Wind

The SQFlex Wind performance range on page 4 is based on these data:

- average wind speed, measured over one month
- calculations according to Weibull's factor k = 2
- continuous operation over 24 hours.

Specific performance charts

The specific performance charts on pages 27 to 32 are based on the following guidelines:





























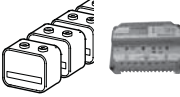







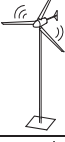





- All curves show mean values.
- The curves must not be used as guarantee curves.
- Typical deviation: ± 15 %.
- The measurements have been made at a water temperature of +20 °C.
- The curves apply to a kinematic viscosity of 1 mm²/s (1 cSt). If the pump is used for liquids with a viscosity higher than that of water, this will reduce the head and increase the power consumption.

Pressure loss

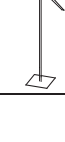
The QH curves are inclusive of inlet and valve losses at actual speed.

System overview

The SQFlex system can be used in a number of combinations as shown in the table below.

System	System components							
	Pump	Solar panels★	Wind turbine	Generator/battery	Charge controller	Switch box or breaker box	Control unit	Optional extras
SQFlex Solar See page 11.								
						IO 50		
SQFlex Solar with CU 200 and level switch See page 12.								 (★★)
							CU 200	(★★)
SQFlex Solar with backup generator See page 13.								
							IO 101	
SQFlex Solar with CU 200 and backup generator See page 14.							 	 (★★)
							IO 101 CU 200	(★★)
SQFlex Solar with backup batteries See page 15.							 	  Pressure tank Pressure switch
							IO 50 or IO 101 (★★)	
SQFlex Wind See page 16.								
							IO 102	
SQFlex Wind with CU 200 and level switch See page 17.							 	 (★★)
							IO 102 CU 200	(★★)
SQFlex Combi See page 18.								
							IO 102	
SQFlex Combi with CU 200 and level switch See page 19.							 	 (★★)
							IO 102 CU 200	(★★)
SQFlex system with generator as power supply See page 20.								
							IO 101	

★ For number of solar panels required, please consult the sizing tool. See [Grundfos Product Center](#) on page 47.

★★ Optional.

2. Features and benefits

Dry-running protection

The SQF pump is protected against dry running in order to prevent damage to the pump. The dry-running protection is activated by a water level electrode placed on the motor cable 0.3 to 0.6 m above the pump, depending on pump type.

The water level electrode measures the contact resistance to the motor sleeve through the water. When the water level falls below the water level electrode, the pump will be cut out. The pump will automatically cut in again five minutes after the water level is above the water level electrode.

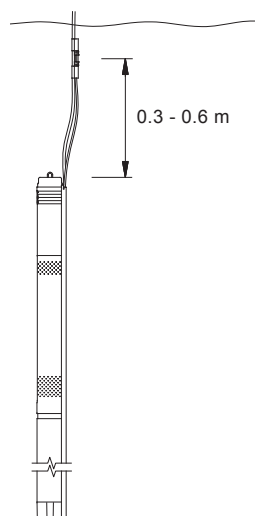

Fig. 2 Vertical installation

TM02 2436 3901

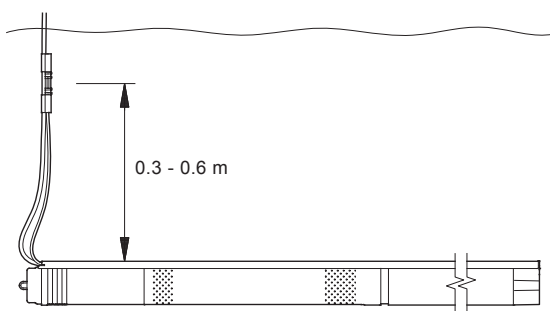

Fig. 3 Horizontal installation

TM02 2435 3901

High efficiency

The MSF 3 motor is a permanent-magnet motor (PM motor) featuring a higher efficiency within the power range compared to a conventional asynchronous motor.

In addition to this, the segmented motor stator contributes considerably to the high efficiency.

The MSF 3 motor is furthermore characterised by a high locked-rotor torque even at low power supply.

Overvoltage and undervoltage protection

Overvoltage and undervoltage may occur in case of unstable power supply or a faulty installation.

The pump will be cut out if the voltage falls outside the permissible voltage range. The motor is automatically cut in when the voltage is again within the permissible voltage range. Therefore no extra protection relay is needed.

Note: The MSF 3 motor is protected against transients from the power supply according to EN/IEC 61000-4-5 (6 kV). In areas with high lightning intensity, we recommend external lightning protection.

Overload protection

In case the upper load limit is exceeded, the motor will automatically compensate for this by reducing the speed. If the speed falls below minimum speed, the motor will be cut out automatically.

The motor will remain cut out for 30 seconds after which period the pump will automatically attempt to restart.

The overload protection prevents burnout of the motor. Consequently, no extra motor protection is required.

Overtemperature protection

A permanent-magnet motor gives off very little heat to its surroundings. In combination with an efficient internal circulation system leading the heat away from the rotor, stator and bearings, this fact ensures optimum operating conditions for the motor.

As an extra protection, the electronic unit has a built-in temperature sensor. When the temperature rises above +85 °C, the motor is automatically cut out. When the temperature has dropped to +75 °C, the motor is automatically cut in again.

Maximum Power Point Tracking (MPPT)

The built-in electronic unit gives the SQFlex system a number of advantages compared to conventional products. One of these advantages is the built-in microprocessor with MPPT (Maximum Power Point Tracking).

Thanks to the MPPT function, the pump duty point is continuously optimised according to the input power available. MPPT is only available for pumps connected to DC supply.

Wide voltage range

The wide voltage range enables the motor to operate at any voltage from 30-300 VDC or 90-240 VAC. This makes installation and sizing especially easy.

Reliability

The MSF 3 motor has been developed with a view to high reliability which is achieved through the following features:

- carbon/ceramic bearings
- excellent starting capabilities
- various protection facilities.

Installation

The following features ensure simple installation of the SQF pump:

- Low weight ensuring user-friendly handling.
- Installation in 3", 4" or larger boreholes.
- Only an on/off switch is needed, which means that no extra motor starter/starter box is necessary.
- SQF is available with cable and socket.

Note: Horizontal installation requires the water level electrode to be placed minimum 0.3 to 0.6 m above the pump to ensure the dry-running protection.

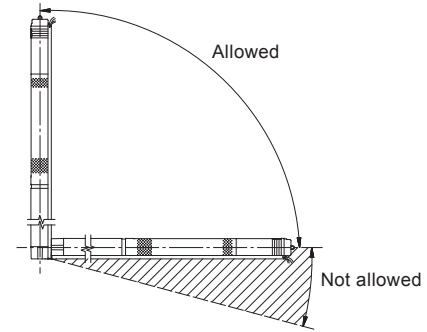

TM02 2246 3901

Fig. 4 Installation of SQF pumps

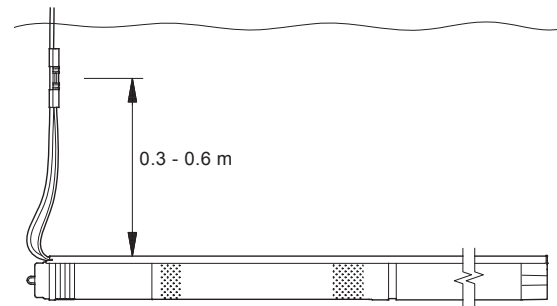

TM02 2435 3901

Fig. 5 Horizontal installation

Service

The modular pump and motor design facilitates installation and service. The cable and the end cover with socket are fitted to the pump with screws to enable replacement.

3. Applications

SQFlex Solar

The SQFlex solar system is the simplest of the range of SQFlex systems.

Benefits

The protective circuit incorporated in the motor electronic unit cuts out the pump in case of dry running or similar situations.

By using the IO 50, the power supply to the pump can be switched off manually, for example in these cases:

- There is no need for water supply.
- The system requires service.

Other benefits:

- easy installation
- maintenance confined to periodic cleaning of the solar panels
- few and simple components.

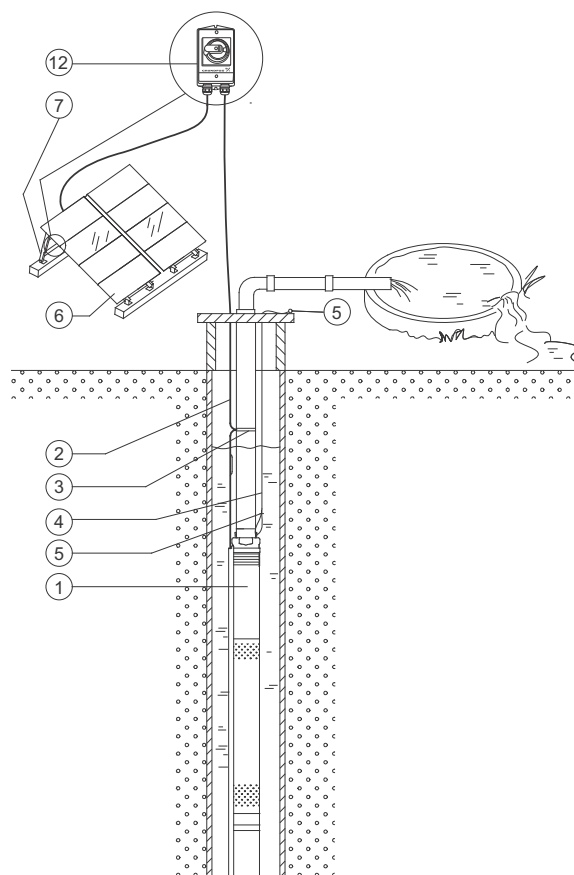

TM02 2304 1013

Fig. 6 SQFlex Solar

Pos.	Description
1	SQF pump
2	Submersible drop cable
3	Cable clips
4	Straining wire
5	Wire clamps
6	Solar panels
7	Support structure
12	IO 50 SQFlex switch box

Note: For the number of solar panels required, please consult the sizing tool. See [Grundfos Product Center](#) on page 47.

SQFlex Solar with CU 200 and level switch

The SQFlex Solar system allows solar energy to be stored as water in a reservoir.

SQFlex Solar systems with a water reservoir are used in cases such as:

- There is a need for water supply at night.
- For short periods, the solar energy is insufficient to run the pump.
- There is a need for a backup water source.

Benefits

Combined with CU 200, the level switch acts as a pump cut-out function when the water reservoir is full.

CU 200 offers indication of status:

- full water reservoir (level switch activated)
- pump operation
- input power.

CU 200 indicates operational stoppage these cases:

- dry running
- service (see page 21)
- insufficient energy supply.

Other benefits:

- easy installation
- maintenance confined to periodic cleaning of the solar panels
- few and simple components.

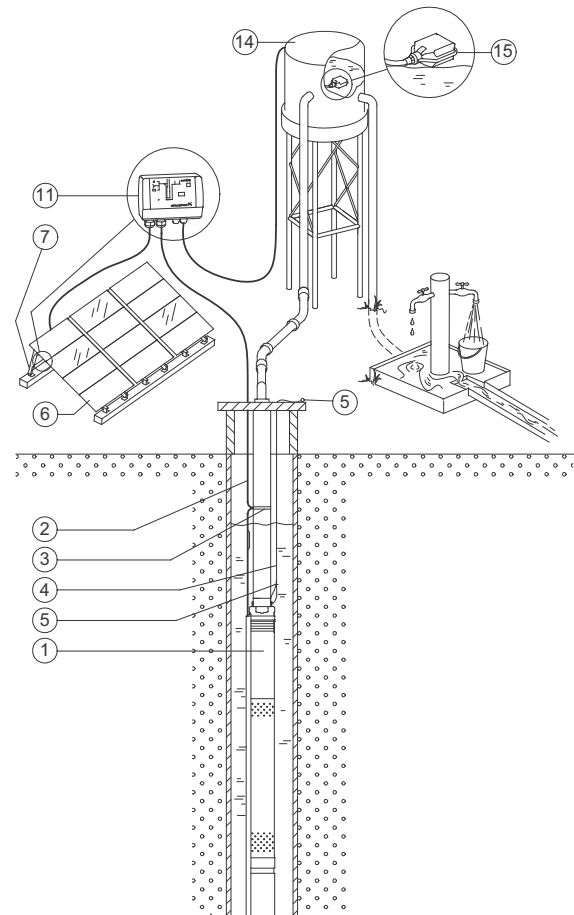

TM02 2305 1013

Fig. 7 SQFlex Solar with CU 200 and level switch

Pos.	Description
1	SQF pump
2	Submersible drop cable
3	Cable clips
4	Straining wire
5	Wire clamps
6	Solar panels
7	Support structure
11	CU 200 SQFlex control unit
14	Water reservoir
15	Level switch

Note: For the number of solar panels required, please consult the sizing tool. See [Grundfos Product Center](#) on page 47.

SQFlex Solar with backup generator

During periods of limited solar energy, the SQFlex Solar system provides reliable water supply.

The system is connected to an external backup generator via the IO 101.

The system switches automatically to operation via generator when the generator is started.

If the generator is stopped manually or runs out of fuel, the IO 101 will automatically change back to operation via solar energy.

Benefits

The system offers water supply during the night or during periods of insufficient solar energy.

Other benefits:

- easy installation
- maintenance confined to periodic cleaning of the solar panels
- few and simple components
- flexibility in terms of energy supply.

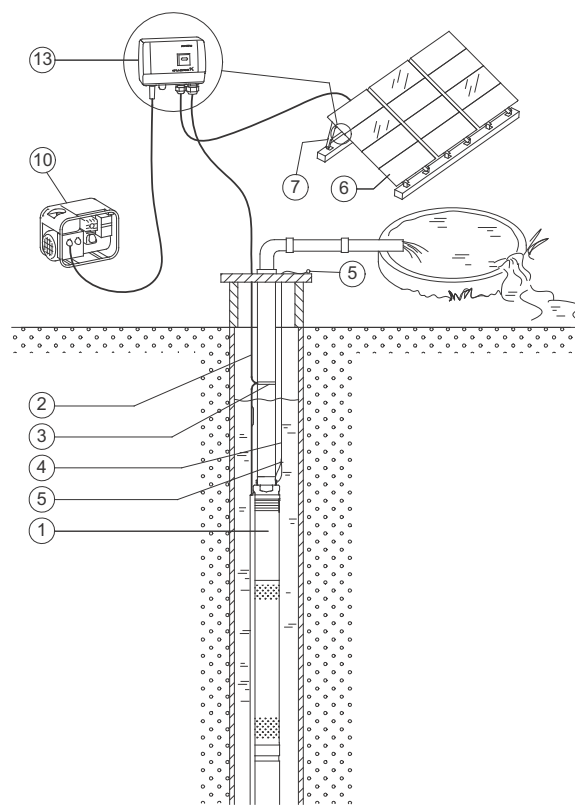

TM02 2309 1013

Fig. 8 SQFlex Solar with backup generator

Pos.	Description
1	SQF pump
2	Submersible drop cable
3	Cable clips
4	Straining wire
5	Wire clamps
6	Solar panels
7	Support structure
10	Diesel- or petrol-driven generator
13	IO 101 SQFlex switch box

Note: For the number of solar panels required, please consult the sizing tool. See [Grundfos Product Center](#) on page 47.

SQFlex Solar with CU 200 and backup generator

During periods of limited solar energy, the SQFlex Solar system provides reliable water supply.

The supply of water is ensured by a diesel- or petrol-driven generator connected to the system via the IO 101.

The system switches automatically to operation via generator when the generator is started.

If the generator is stopped manually or runs out of fuel, the IO 101 will automatically change back to operation via solar energy.

Benefits

The system offers water supply during the night or during periods of insufficient solar energy.

Other benefits:

- easy installation
- maintenance confined to periodic cleaning of the solar panels
- few and simple components
- flexibility in terms of energy supply.

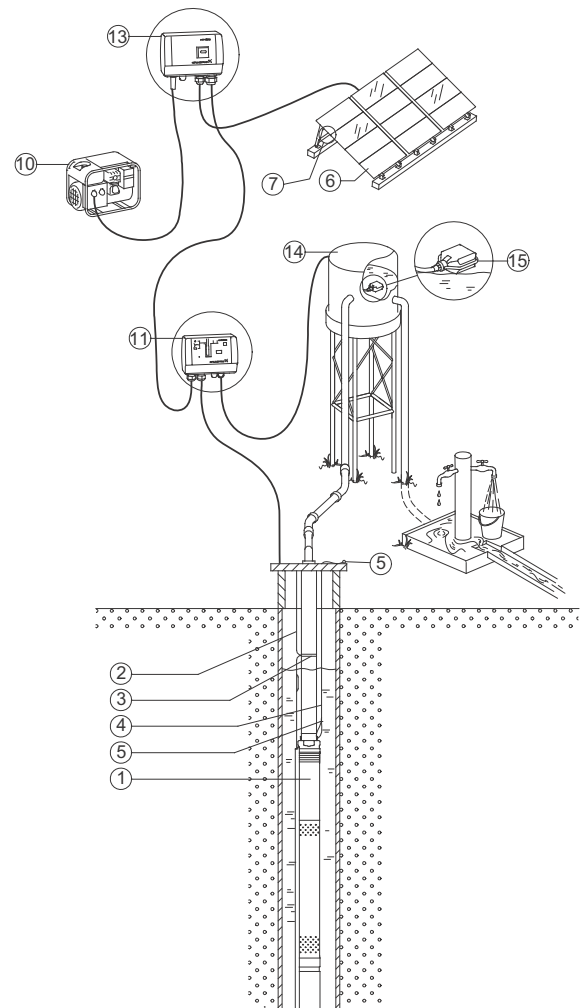

TM03 5497 1013

Fig. 9 SQFlex Solar with CU 200 and backup generator

Pos.	Description
1	SQF pump
2	Submersible drop cable
3	Cable clips
4	Straining wire
5	Wire clamps
6	Solar panels
7	Support structure
10	Diesel- or petrol-driven generator
11	CU 200 SQFlex control unit
13	IO 101 SQFlex switch box
14	Water reservoir
15	Level switch

Note: For the number of solar panels required, please consult the sizing tool. See [Grundfos Product Center](#) on page 47.

SQFlex Solar with backup batteries

During periods of limited solar energy, the SQFlex Solar system provides reliable water supply.

The supply of water is ensured by backup batteries connected to the system via the charge controller.

The system is connected as shown in fig. 10.

- Power will be provided by the solar panels wired to produce minimum 60 VDC and maximum 110 VDC.
 - Power from the solar panels will be fed into a 48 VDC charge controller, which will regulate the current fed to the batteries.
 - From the charge controller, power passes into the battery bank, which consists of the number of appropriately sized batteries, wired in series to achieve 48 VDC (rated) output.
 - Power is drawn from the battery bank and routed through a CU 200.
- Option:** An IO 50 or IO 101 is to be installed to enable disconnection of the DC voltage. If an IO 101 is installed, it is possible to add a generator to the system.
- Power is run from CU 200 to the SQFlex pump.

Benefits

The system offers water supply during the night or during periods of insufficient solar energy.

Other benefits:

- easy installation
- maintenance confined to periodic cleaning of the solar panels
- few and simple components
- flexibility in terms of energy supply.

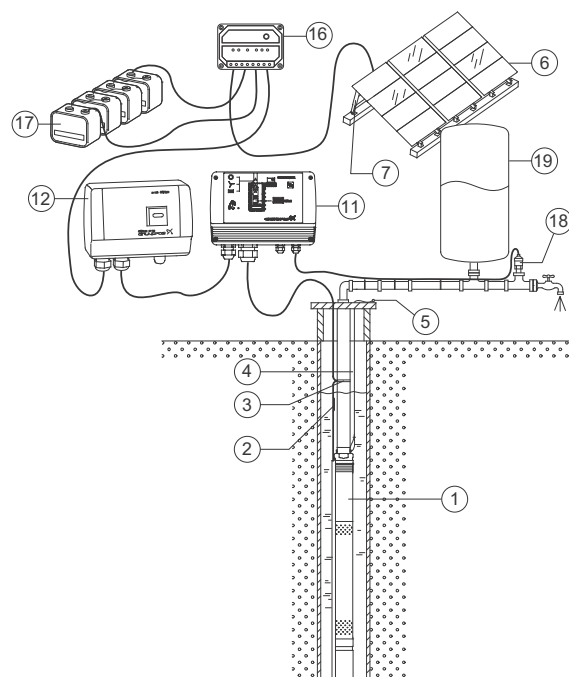

TM03 4232 1013

Fig. 10 SQFlex Solar with backup batteries

Pos.	Description
1	SQF pump
2	Submersible drop cable
3	Cable clips
4	Straining wire
5	Wire clamps
6	Solar panels
7	Support structure
11	CU 200 SQFlex control unit
12	IO 101 SQFlex switch box (optional)
16	Charge controller
17	Batteries
18	Pressure switch
19	Pressure tank

Note: For the number of solar panels required, please consult the sizing tool. See [Grundfos Product Center](#) on page 47.

SQFlex Wind

The SQFlex Wind system is based on wind energy as the only energy source for pump operation.

The system is suitable for installation in areas where the wind is almost constant seen over a period of time. As the turbine noise level increases with the wind speed, we do not recommend that you install the wind turbine near a residence.

Benefits

The IO 102 makes it possible to slow down or stop the wind turbine in these cases:

- There is no need for water supply.
- The system requires service.

Other benefits:

- easy installation
- a minimum of maintenance
- few and simple components.

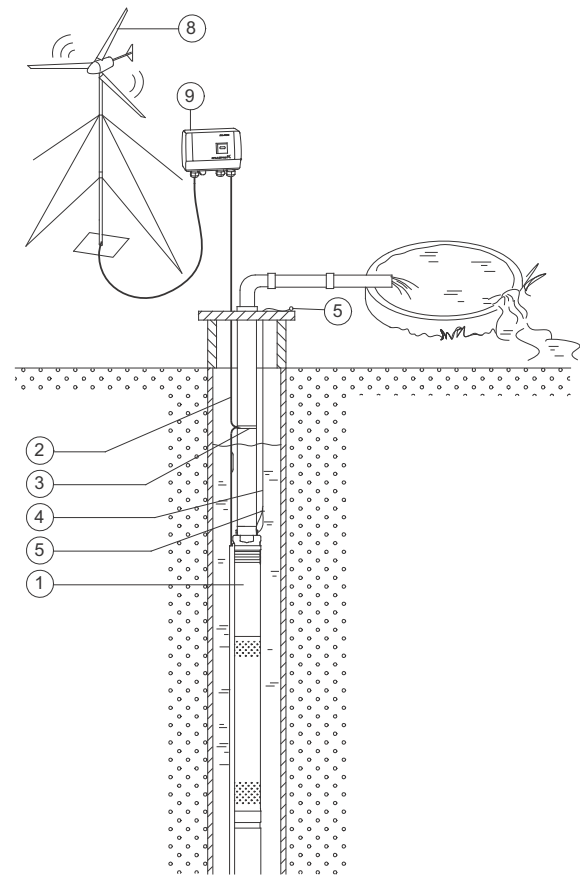

TM02 2306 1013

Fig. 11 SQFlex Wind

Pos.	Description
1	SQF pump
2	Submersible drop cable
3	Cable clips
4	Straining wire
5	Wire clamps
8	Wind turbine
9	IO 102 SQFlex breaker box

SQFlex Wind with CU 200 and level switch

The SQFlex Wind system allows wind energy to be stored as water in a reservoir.

SQFlex Wind systems with a water reservoir are used in these cases:

- For short periods, the wind energy is insufficient to run the pump.
- There is a need for a backup water source.

As the turbine noise level increases with the wind speed, we do not recommend that you install the wind turbine near a residence.

Benefits

Combined with CU 200, the level switch acts as a pump cut-out function when the water reservoir is full.

CU 200 offers indication of status:

- full water reservoir (level switch activated)
- pump operation
- input power.

CU 200 indicates operational stoppage in these cases:

- dry running
- service (see page 21)
- insufficient energy supply.

The IO 102 makes it possible to switch off the power supply in the system and to slow down or stop the wind turbine in these cases:

- There is no need for water supply.
- The system requires service.

Other benefits:

- easy installation
- a minimum of maintenance
- few and simple components.

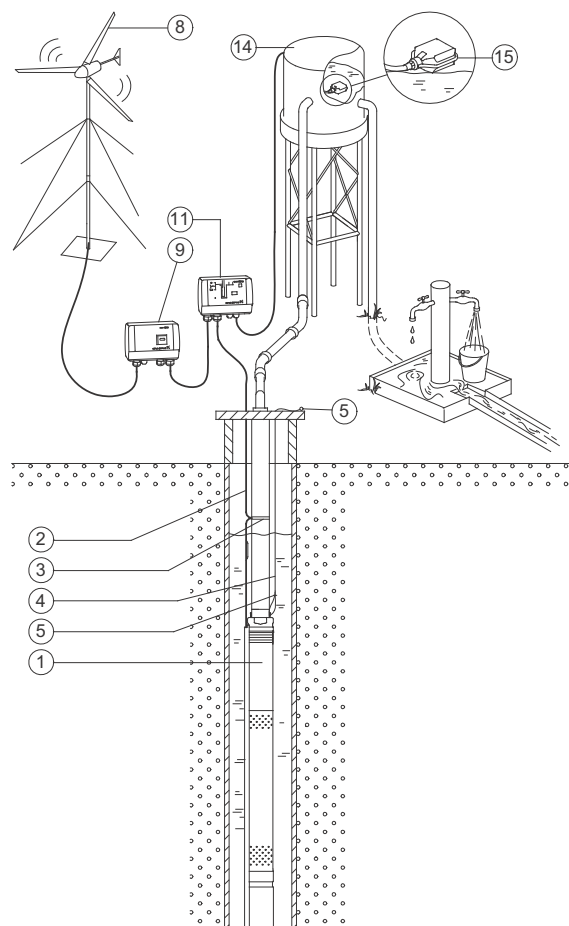

TM02 2308 1013

Fig. 12 SQFlex Wind with CU 200 and level switch

Pos.	Description
1	SQF pump
2	Submersible drop cable
3	Cable clips
4	Straining wire
5	Wire clamps
8	Wind turbine
9	IO 102 SQFlex breaker box
11	CU 200 SQFlex control unit
14	Water reservoir
15	Level switch

SQFlex Combi

The SQFlex Combi system is ideal in areas where the solar and/or wind energy is sufficient to run the pump.

The energy supply to the pump is a combination of solar and wind energy.

As the turbine noise level increases with the wind speed, we do not recommend that you install the wind turbine near a residence.

Benefits

The system offers water supply during the night or during periods of insufficient solar energy.

The IO 102 makes it possible to switch off the power supply in the system and to slow down or stop the wind turbine in these cases:

- There is no need for water supply.
- The system requires service.

Other benefits:

- easy installation
- a minimum of maintenance
- few and simple components.

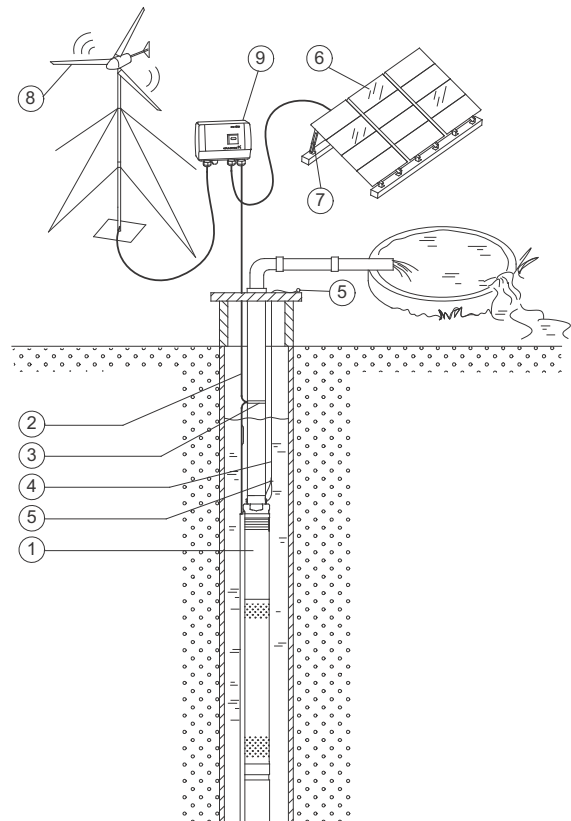

TM02 2307 1013

Fig. 13 SQFlex Combi - combination of solar and wind energy

Pos.	Description
1	SQF pump
2	Submersible drop cable
3	Cable clips
4	Straining wire
5	Wire clamps
6	Solar panels
7	Support structure
8	Wind turbine
9	IO 102 SQFlex breaker box

Note: For the number of solar panels required, please consult the sizing tool. See [Grundfos Product Center](#) on page 47.

SQFlex Combi with CU 200 and level switch

The SQFlex Combi system allows solar and wind energy to be stored as water in a reservoir.

SQFlex Combi systems with a water reservoir are used in these cases:

- For short periods, the solar or wind energy is insufficient to run the pump.
- There is a need for a backup water source.

As the turbine noise level increases with the wind speed, we do not recommend that you install the wind turbine near a residence.

Benefits

Combined with CU 200, the level switch acts as a pump cut-out function when the water reservoir is full.

CU 200 offers indication of status:

- full water reservoir (level switch activated)
- pump operation
- input power.

CU 200 indicates operational stoppage in these cases:

- dry running
- service (see page 21)
- insufficient energy supply.

The IO 102 makes it possible to switch off the power supply in the system and to slow down or stop the wind turbine in these cases:

- There is no need for water supply.
- The system requires service.

Other benefits:

- easy installation
- a minimum of maintenance
- few and simple components.

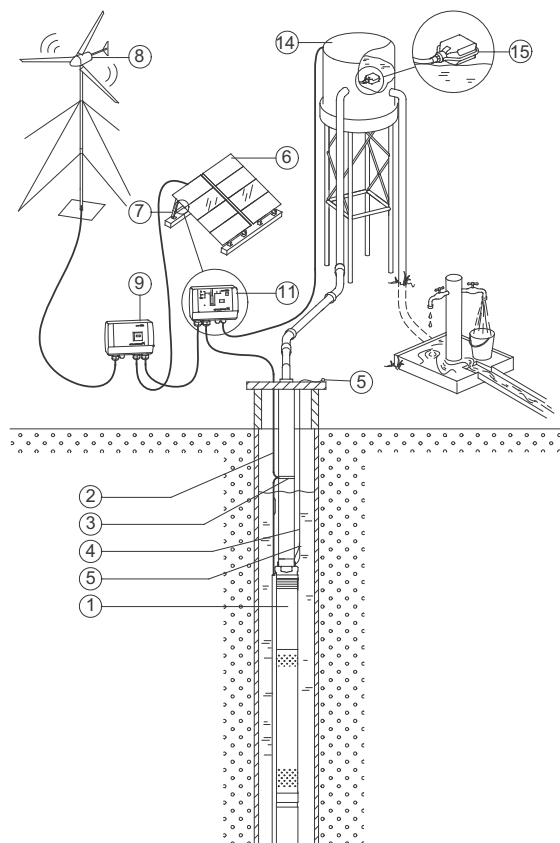

TM02 23 10 1013

Fig. 14 SQFlex Combi with CU 200 and level switch

Pos.	Description
1	SQF pump
2	Submersible drop cable
3	Cable clips
4	Straining wire
5	Wire clamps
6	Solar panels
7	Support structure
8	Wind turbine
9	IO 102 SQFlex breaker box
11	CU 200 SQFlex control unit
14	Water reservoir
15	Level switch

Note: For the number of solar panels required, please consult the sizing tool. See [Grundfos Product Center](#) on page 47.

SQFlex system with generator as power supply

The SQFlex system is connected to a diesel- or petrol-driven generator.

Benefits

The system offers water supply 24 hours a day, independently of the weather.

Other benefits:

- easy installation
- a minimum of maintenance
- few and simple components.

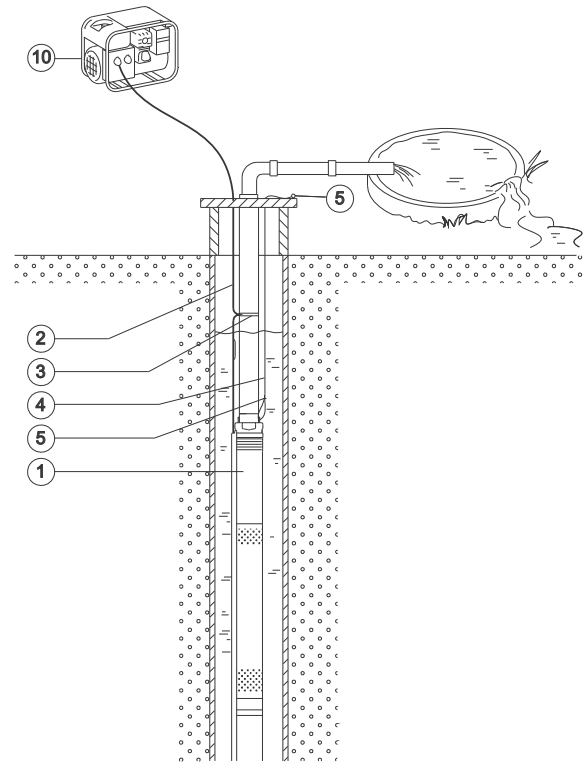

TM02 2311 1013

Fig. 15 SQFlex system with generator as power supply

Pos.	Description
1	SQF pump
2	Submersible drop cable
3	Cable clips
4	Straining wire
5	Wire clamps
10	Generator

4. System components

SQF submersible pump

The SQF pump is available as a complete unit only. The complete SQF pump consists of these components:

- motor
- 2.0 m cable with water-level electrode and socket
- cable guard.

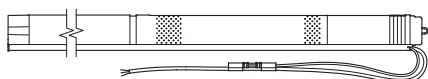

TM02 2217 3901

Fig. 16 SQF pump

The MSF motor is to be connected to the power supply as shown in fig. 17.

As the integrated electronic unit enables the motor to handle both DC and AC supply voltages, it makes no difference how the wires "+" and "-" or "N" and "L" are connected.

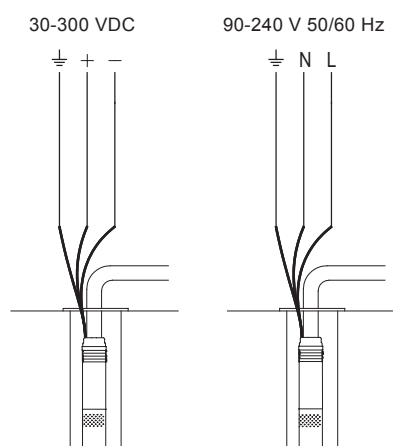

Fig. 17 Wiring diagram

CU 200 SQFlex control unit

CU 200 is a combined status, control and communication unit especially developed for the SQFlex system. CU 200 also enables connection of a level switch.

CU 200 incorporates cable entries for these connections:

- power supply (pos. 6)
- pump (pos. 7)
- earth (pos. 8)
- level switch (pos. 9).

The position numbers in brackets refer to fig. 18.

Communication between CU 200 and the pump takes place via the pump power supply cable. This is called mains-borne signalling (or power line communication), and this principle means that no extra cables between CU 200 and the pump are required.

It is possible to start, stop and reset the pump with the on/off button (pos. 1).

CU 200 offers system monitoring and alarm indication. The following indications allow the operation of the pump to be monitored:

- Water reservoir is full (level switch) (pos. 2).
- Pump is running (pos. 3).
- Input power (pos. 11).

CU 200 offers the following alarm indications:

- dry running (pos. 10)
- service needed (pos. 5):
 - no contact to pump
 - overvoltage
 - overtemperature
 - overload.

In addition, CU 200 shows the symbols of the energy supply options (pos. 4).

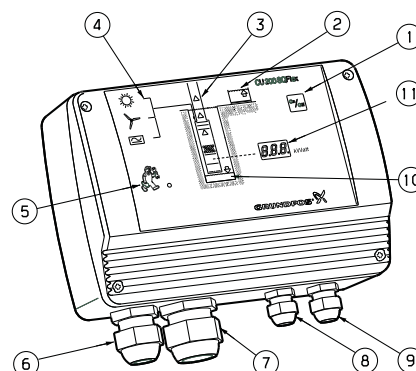

TM02 2437 3901

TM02 2325 1206

Fig. 18 CU 200 elements

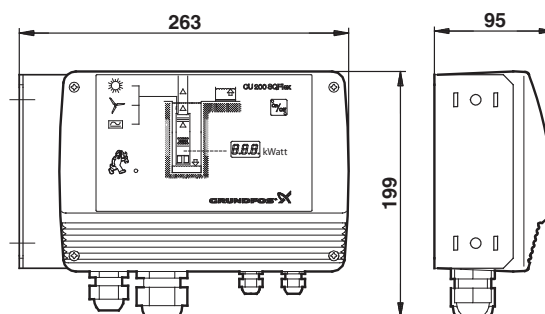

Dimensions stated in mm.

Fig. 19 Dimensions, CU 200

TM02 2323 1206

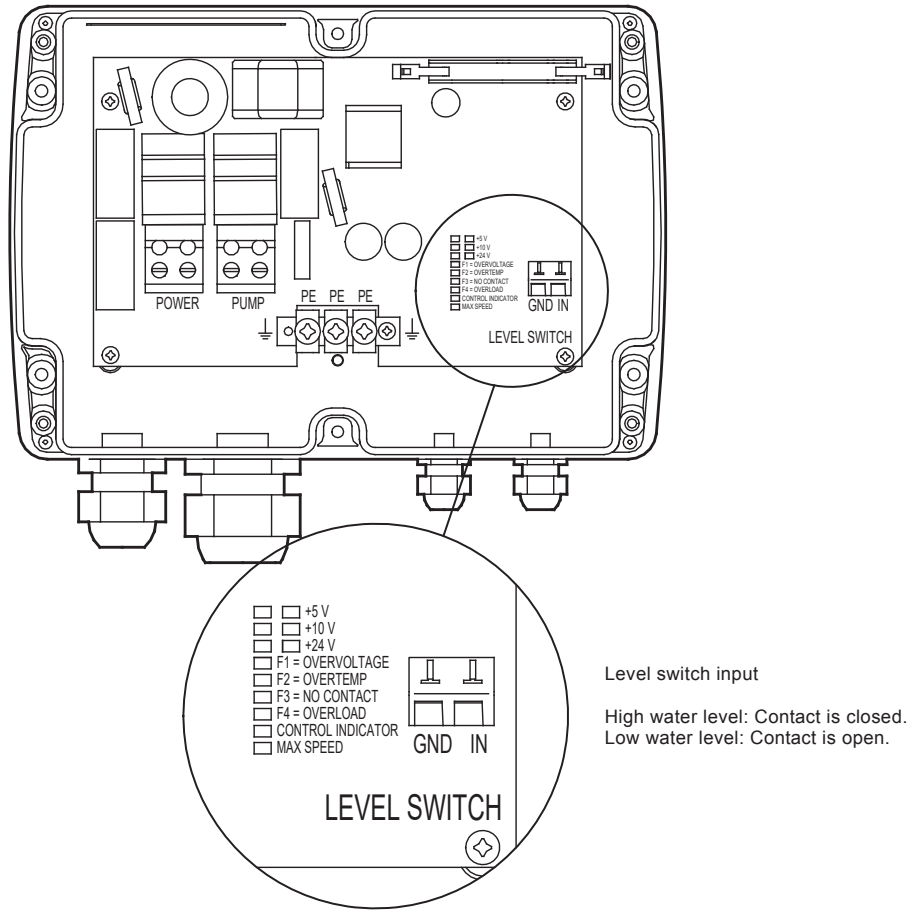

Fig. 20 Electrical connections, CU 200

TM02 2515 4401

CIU 273 SQFlex GRM control unit

The CIU 273 SQFlex is designed to work directly with the SQFlex pump and is a combined monitoring, control and communication unit for the SQFlex pump. CIU 273 enables monitoring the system operation anywhere in the world through Grundfos Remote Monitoring. Moreover, CIU 273 enables connection of a start/stop switch, level switch and pulsating water meter.

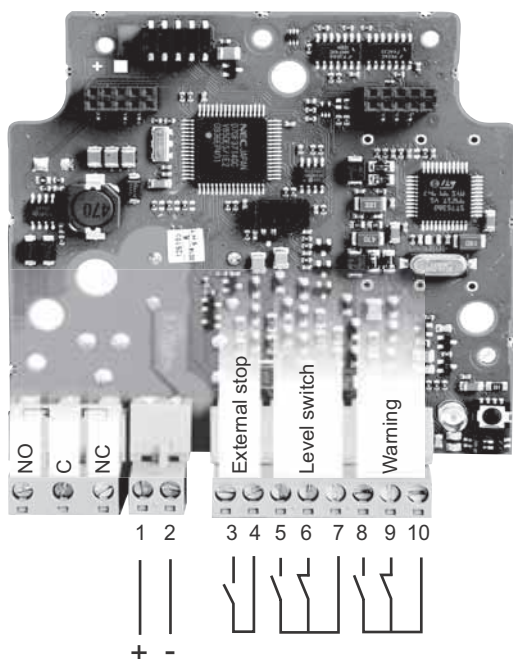

Fig. 21 Electrical connections, CIU 273

Communication between CIU 273 and the pump takes place via the pump power supply cable. This is called mains-borne signalling (or power line communication), and this principle means that no extra cables between CIU 273 and the pump are required.

It is possible to start, stop and reset the pump with the start/stop switch.

CIU 273 offers system monitoring and alarm indication.

The following indications allow the operation of the pump to be monitored:

- Water reservoir is full (level switch).
- Pump is running.

CIU 273 offers the following alarm indications:

- dry running
- no contact to pump
- overvoltage
- overtemperature
- overload.

Note: CIU 273 can replace CU 200 in the installation.



TM05 6101 4512

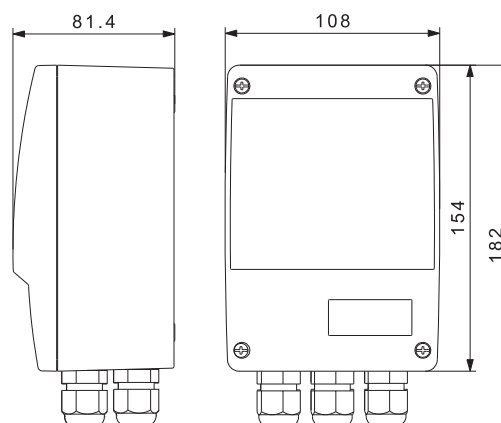

Dimensions stated in mm.

Fig. 22 Dimensions, CIU 273

TM 05 6100 4512

IO 50 SQFlex switch box

The IO 50 is designed specifically for solar-powered SQFlex systems.

The IO 50 enables manual starting and stopping of the pump in an SQFlex Solar system and functions as a connection box joining all necessary cables.

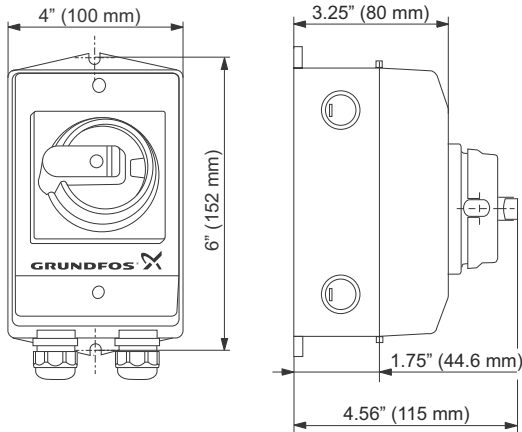

Fig. 23 Dimensions, IO 50

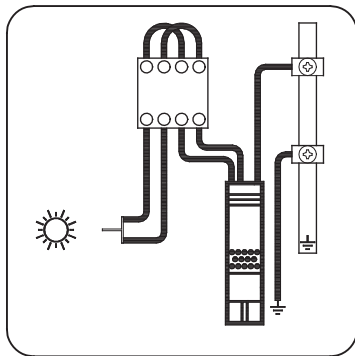

Fig. 24 Wiring diagram, IO 50

IO 101 SQFlex switch box

The IO 101 is designed specifically for solar-powered SQFlex systems.

The IO 101 enables the connection of a backup generator in case of insufficient solar energy. The switching between solar power and generator must be made manually.

In case the generator is stopped manually or runs out of fuel, the IO 101 will automatically change over to the solar panels.

The IO 101 functions as a connection box joining all necessary cables.

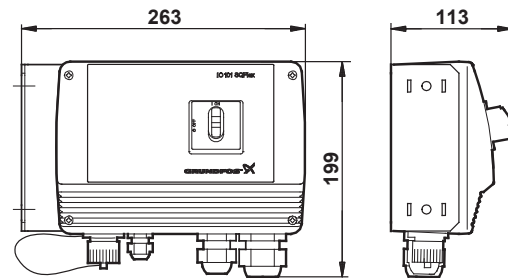

Dimensions stated in mm.

Fig. 25 Dimensions, IO 101

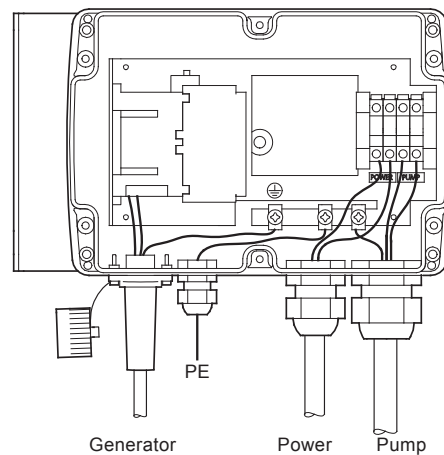

Fig. 26 Electrical connections, IO 101

TM05 5816 2712

TM02 2546 4003

TM02 4058 4701

TM02 4162 5001

IO 102 SQFlex breaker box

The IO 102 is designed specifically for wind-powered SQFlex systems.

The IO 102 enables manual starting and stopping of the pump in an SQFlex Wind system or an SQFlex Combi system.

The on/off switch has a built-in "electrical brake" for the turbine. When the switch is in "off" position, the turbine stops or slows down.

The IO 102 rectifies the three-phase AC voltage from the wind turbine into DC voltage. Furthermore, the IO 102 enables the combination of wind energy from the wind turbine and solar energy from the solar panels.

The IO 102 functions as a connection box joining all necessary cables.

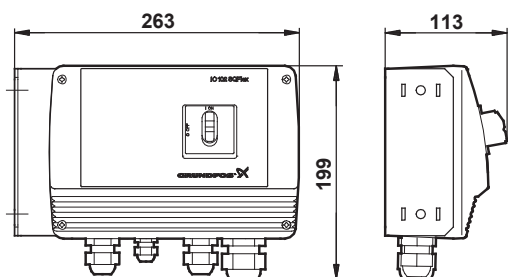

Dimensions stated in mm.

Fig. 27 Dimensions, IO 102

TM02 4232 4003

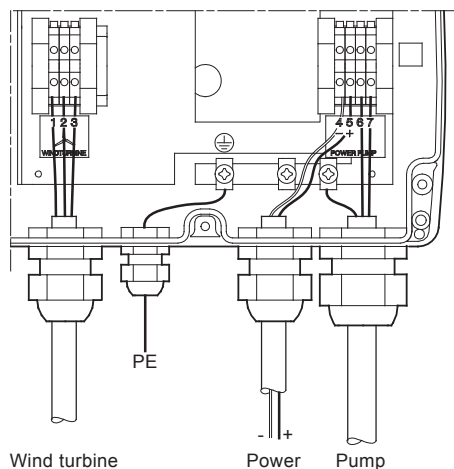

Fig. 28 Electrical connections, IO 102

TM02 4312 0502

Charge controller

The charge controller is used when a battery backup system is installed with an SQFlex pumping system. These systems are typically used in applications where the pump is not running during most of the peak sun hours of the day, or where it is impossible or impractical to store large volumes of water. Examples include remote homes or cabins, automatic livestock waterers and very low-yielding wells.

The charge controller is a fully automatic battery charger, and the only setting required is the selection of battery type.

There are three battery types available:

- gel battery
- sealed battery
- flooded battery.

The charge controller enables manual disconnection of the pump, the solar modules or both at the same time.

Wind turbine

The wind turbine should have a working voltage range of 30 to maximum 220 VAC, single- or three-phase.

The IO 102 functions as a breaker box and must be included in SQFlex Wind systems.

Note: The IO 102 must be ordered separately.

Generator

The generator can be either diesel- or petrol-driven.

The generator must be running steadily before the pump is cut in.

5. System sizing

Sizing of SQFlex system

Grundfos has developed an online-based sizing tool enabling the sizing of SQFlex systems.

See [Grundfos Product Center](#) on page 47. The sizing tool covers both solar- and wind-powered systems.

The following three parameters must be known for the sizing of the optimum SQFlex system:

- installation location
- maximum head required
- quantity of water required.

With a view to the sizing of a correct solar-powered SQFlex system, the world has been divided into six regions:

- North America
- South America
- Australia, New Zealand
- Asia, Pacific
- Southern Africa
- Europe, Middle East, Northern Africa.

Each region is divided into a number of zones according to the solar radiation in kWh/m² per day.

6. Performance curves

SQF 0.6-2

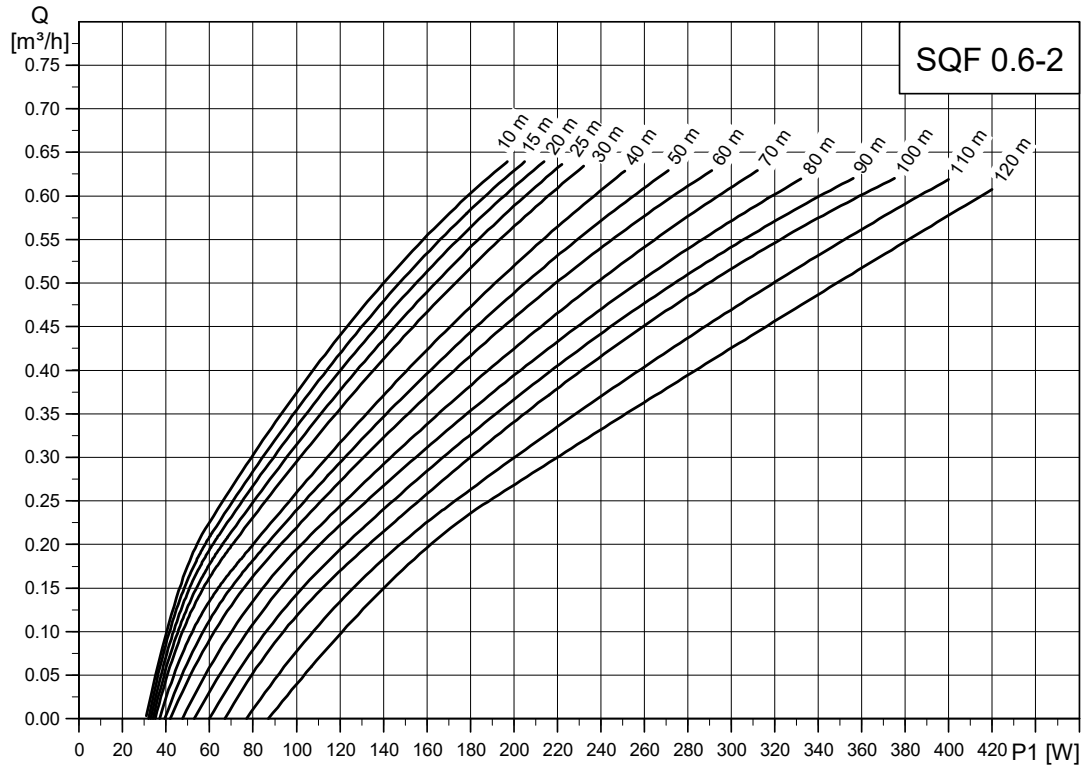

TM02 2338 4107

SQF 0.6-3

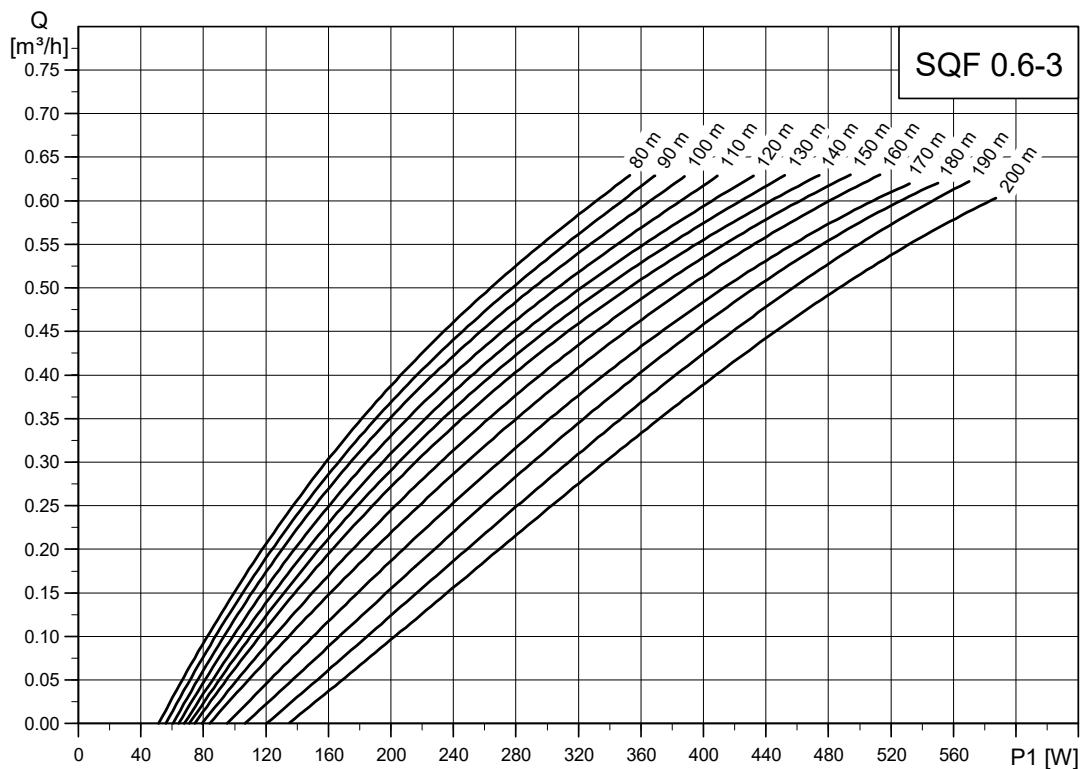

TM03 3926 4107

SQF 1-8

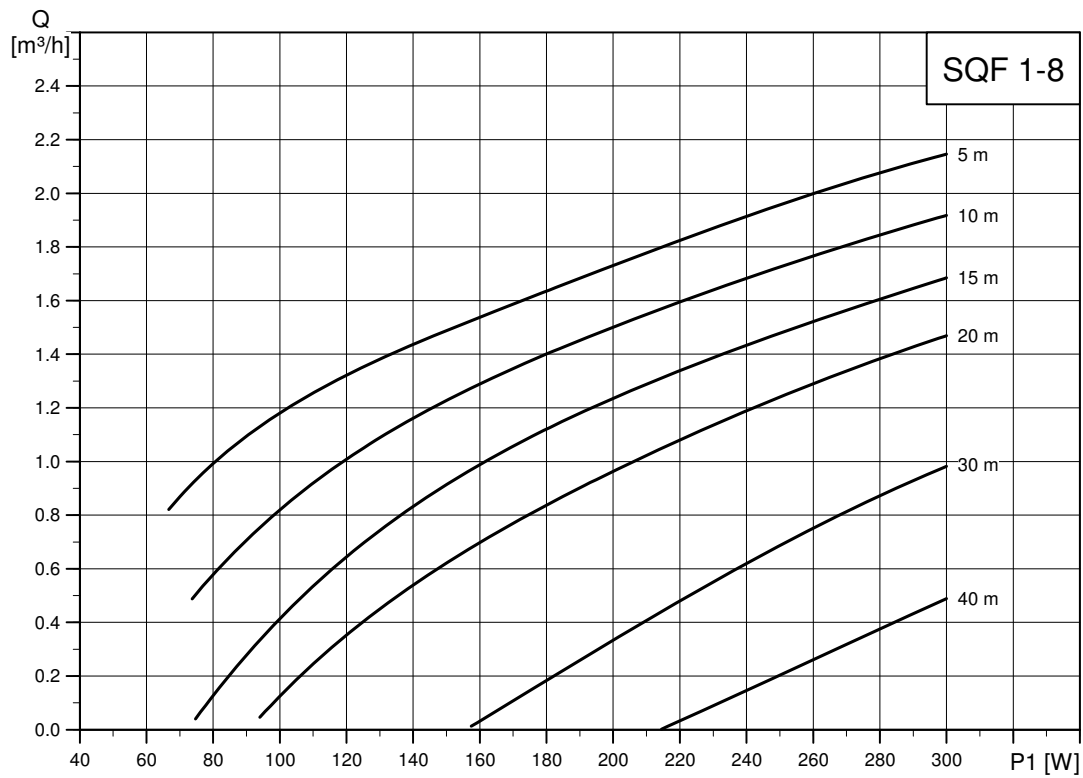

TM06 8847 1217

SQF 1.2-2

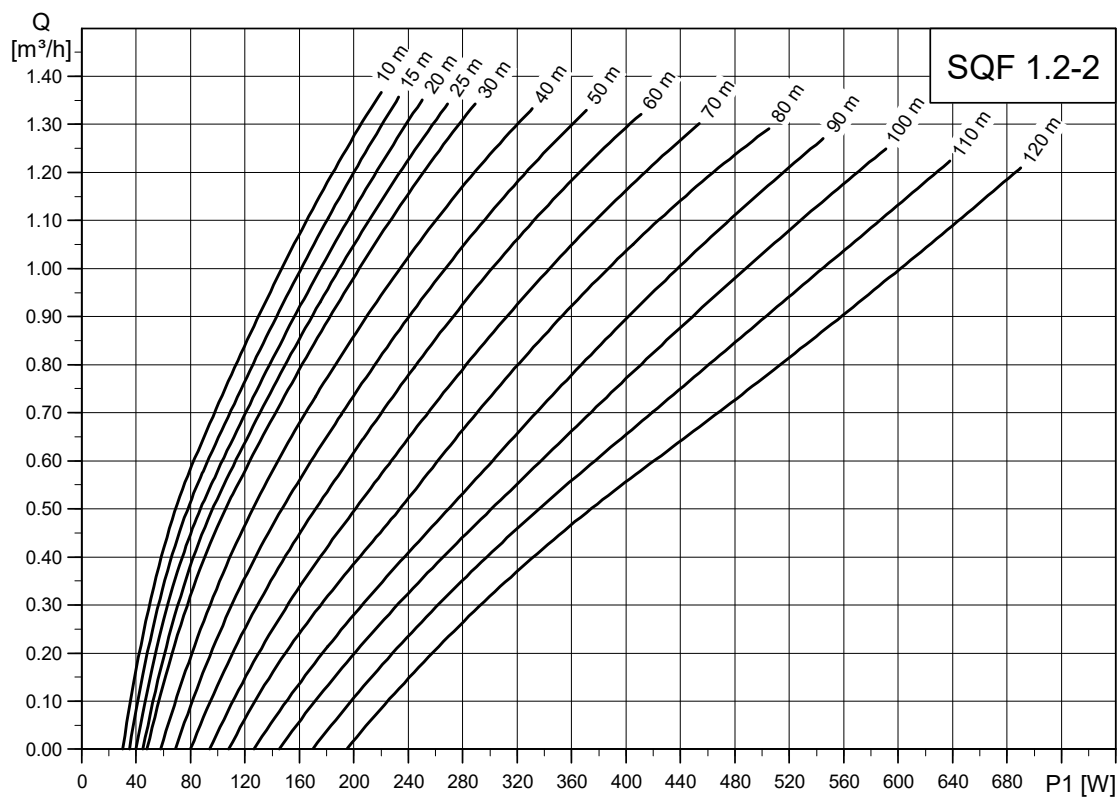

TM02 2339 4107

SQF 1.2-3

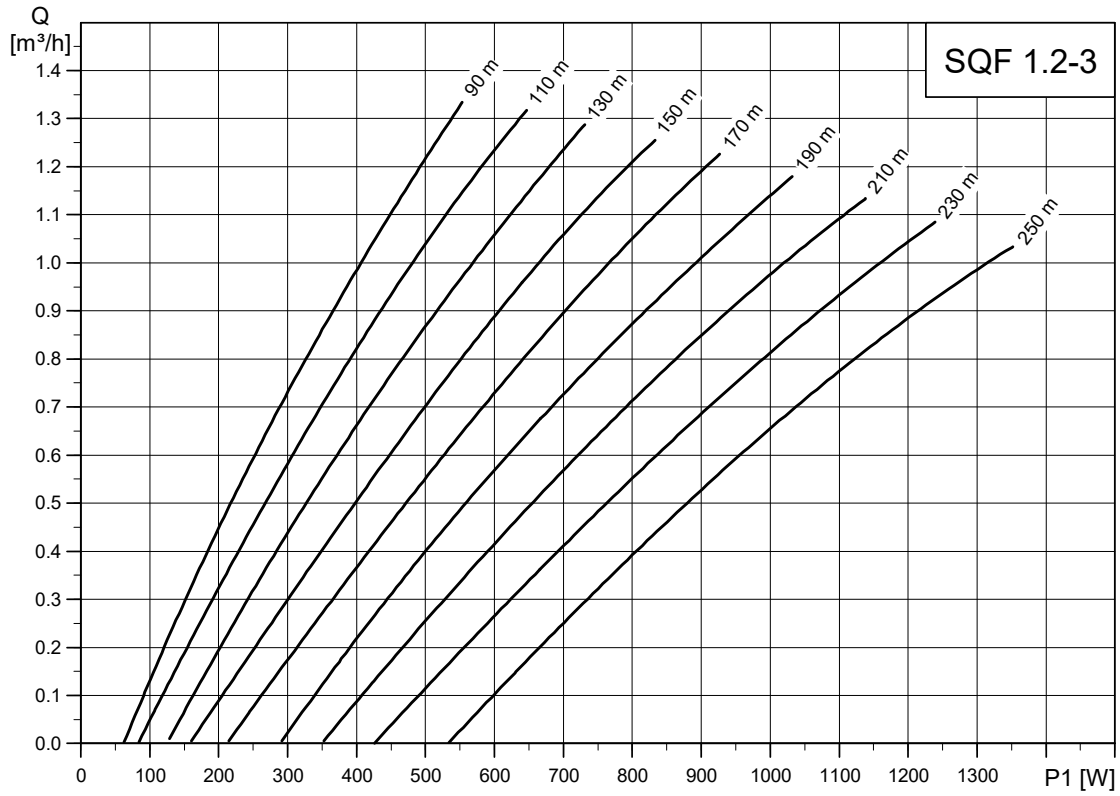

TM04 4606 1709

SQF 2.5-2

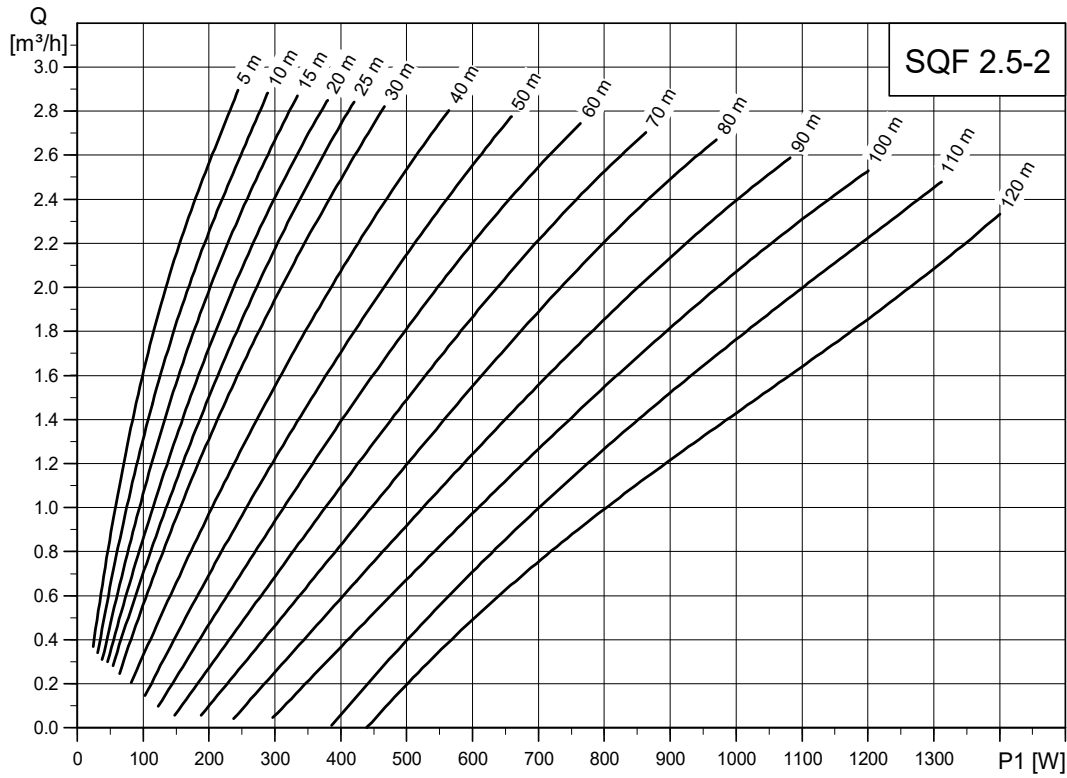

TM02 2340 2409

SQF 3A-10

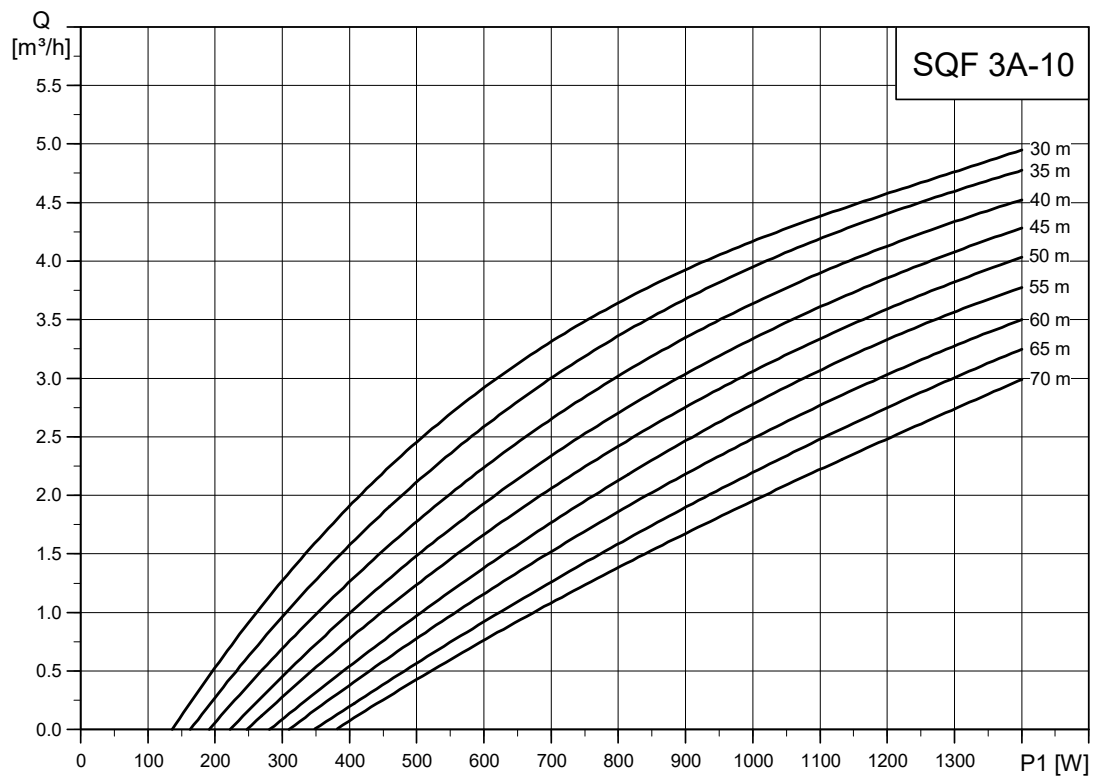

TM03 3927 1206

SQF 5A-3

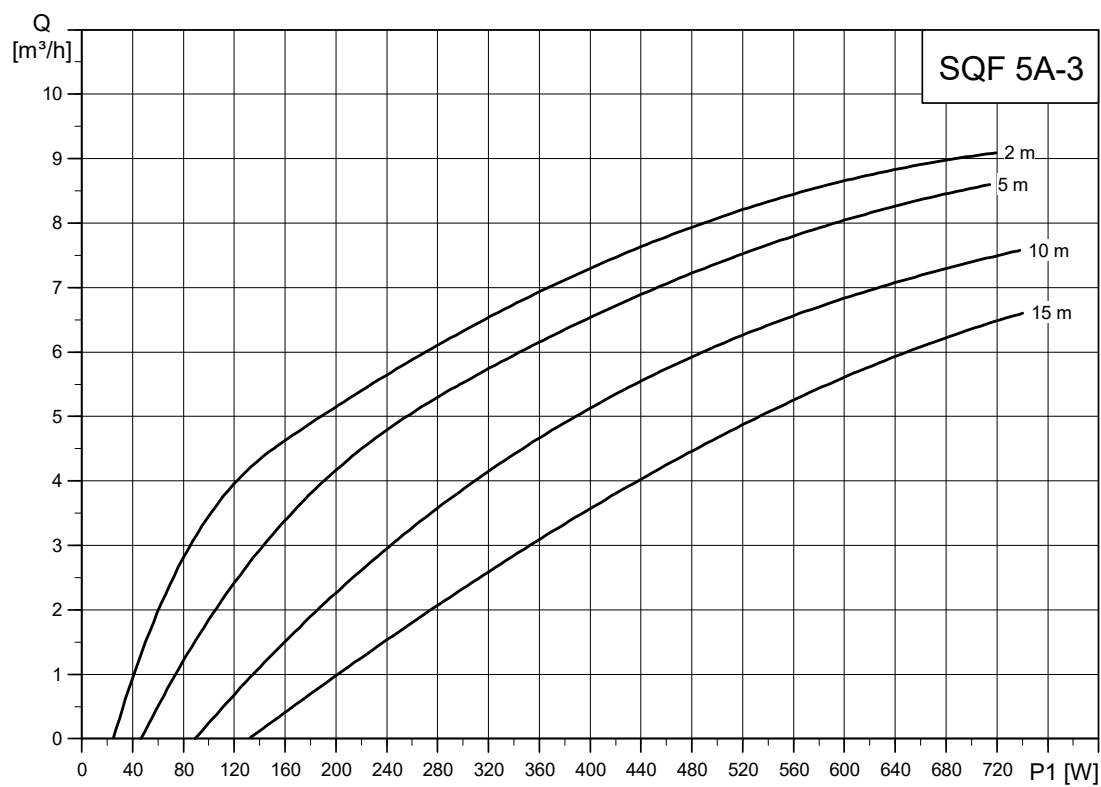

TM02 2341 4107

SQF 5A-7

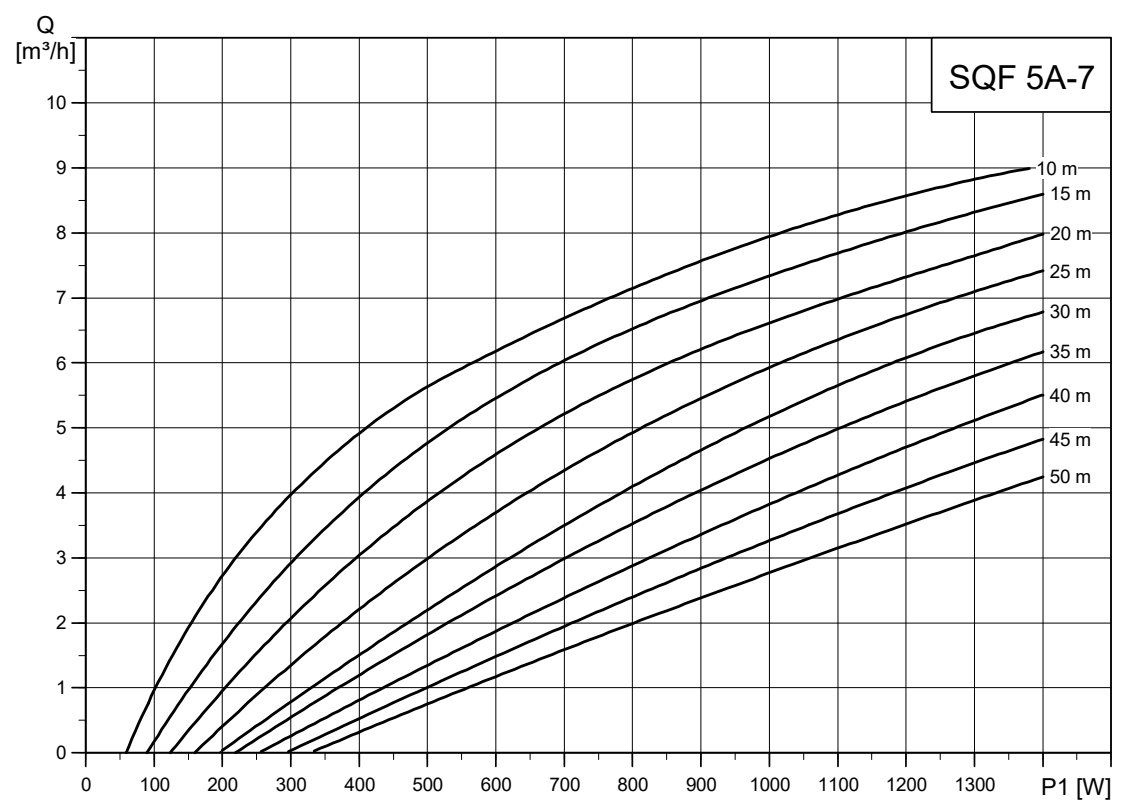

TM02 2342 4107

SQF 7-4

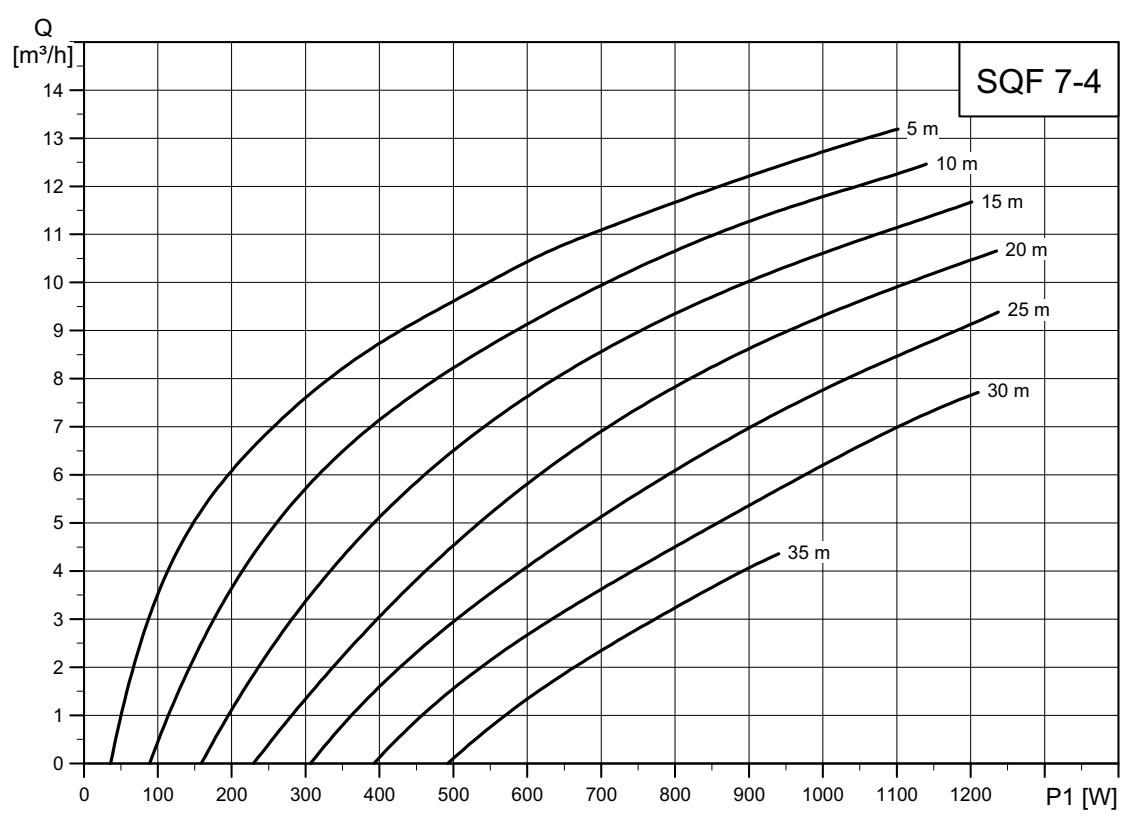

TM02 2343 5006

SQF 9-3

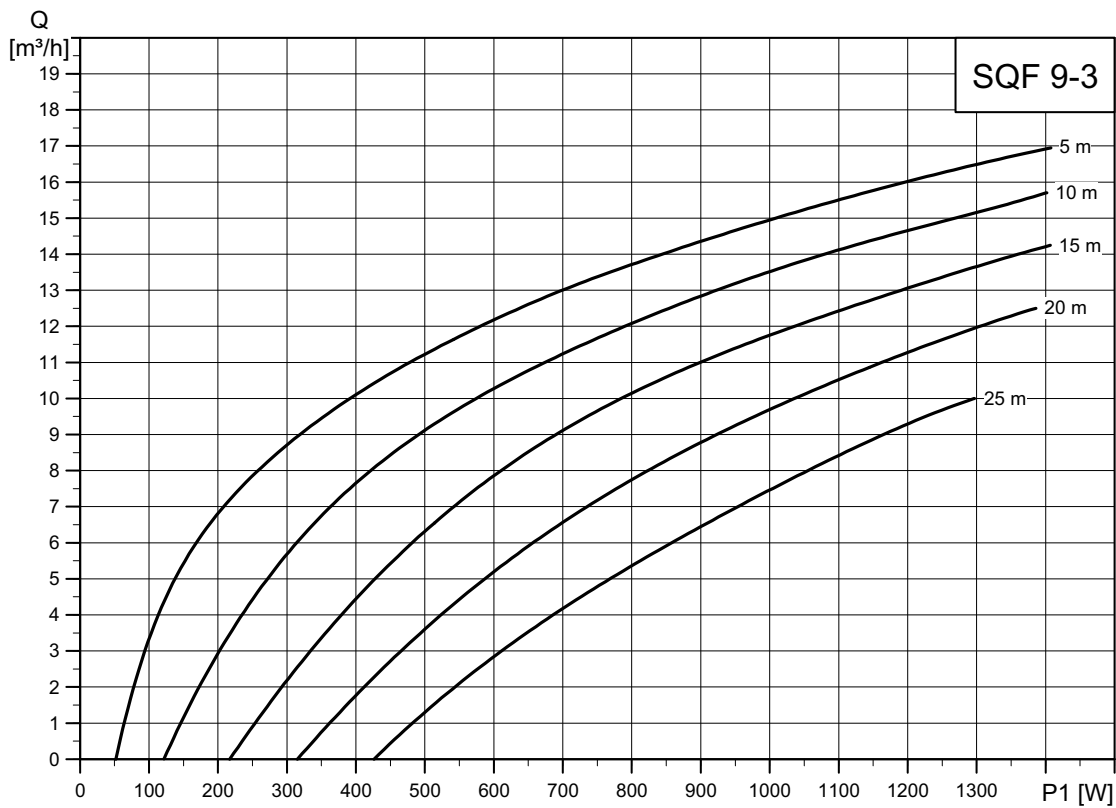

TM03 3928 1206

SQF 14-3

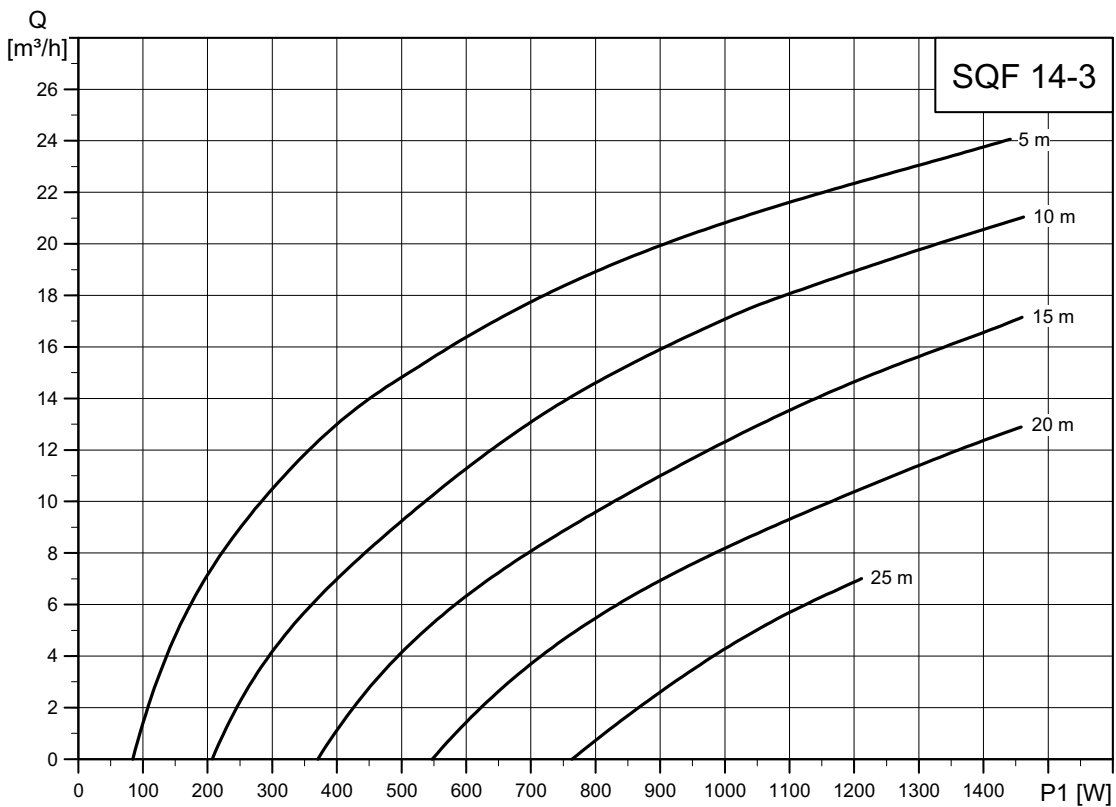

TM03 3929 1206

EuP ready

The SQFlex centrifugal pumps (SP A) are energy-optimised and complies with EuP Directive (Commission Regulation (EC) No 547/2012) which took effect on 1 January 2013. As from this date all pumps are classified/graduated in a new energy efficiency index (MEI).



MEI index

Minimum Efficiency Index (MEI) means the dimensionless scale unit for hydraulic pump efficiency at best efficiency point (BEP), part load (PL) and overload (OL). Regulation in EU sets efficiency requirements to MEI > 0.1 as from 1 January 2013 and MEI > 0.4 as from 1 January 2015. An indicative benchmark for the best-performing water pumps available on the market in 2012 is MEI ≥ 0.70.

Efficiency and MEI index for SQFlex centrifugal (SP A) pumps

Pump type	Pump size	Efficiency [%]	MEI
SQF3A-10	4"	58	≥ 0.70
SQF5A-3	4"	60	≥ 0.56
SQF5A-7	4"	60	≥ 0.56
SQF7-4	4"	69	≥ 0.70
SQF9-3	4"	71	≥ 0.70
SQF14-3	4"	70	≥ 0.44

For more information about the new energy directive, please visit energy.grundfos.com.

7. Technical data

Dimensions and weights

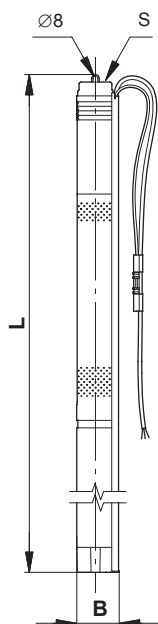

TM02 2209 3901

Pump type	Dimensions [mm]			Net weight [kg]*	Gross weight [kg]*	Shipping volume [m ³]*
	L	B	S			
SQF 0.6-2	1185*	74	Rp 1 1/4	7.6	9.4	0.0242
SQF 0.6-2 N	1185*	74	Rp 1 1/4	7.6	9.4	0.0242
SQF 0.6-3	1235*	74	Rp 1 1/4	7.9	9.7	0.0242
SQF 0.6-3 N	1235*	74	Rp 1 1/4	7.9	9.7	0.0242
SQF 1-8	990	74	Rp 1 1/4	5.6	6.0	0.0110
SQF 1-8N	990	74	Rp 1 1/4	5.6	6.0	0.0110
SQF 1.2-2	1225*	74	Rp 1 1/4	7.9	9.7	0.0242
SQF 1.2-2 N	1225*	74	Rp 1 1/4	7.9	9.7	0.0242
SQF 1.2-3	1295*	74	Rp 1 1/4	8.2	10.0	0.0242
SQF 1.2-3 N	1295*	74	Rp 1 1/4	8.2	10.0	0.0242
SQF 2.5-2	1247*	74	Rp 1 1/4	8.2	10.0	0.0242
SQF 2.5-2 N	1247*	74	Rp 1 1/4	8.2	10.0	0.0242
SQF 3A-10	968	101	Rp 1 1/4	9.5	11.0	0.0282
SQF 3A-10 N	1012	101	Rp 1 1/4	11.1	12.6	0.0282
SQF 5A-3	821	101	Rp 1 1/2	8.1	9.6	0.0282
SQF 5A-3 N	865	101	Rp 1 1/2	9.3	10.8	0.0282
SQF 5A-7	905	101	Rp 1 1/2	8.8	10.3	0.0282
SQF 5A-7 N	949	101	Rp 1 1/2	10.2	11.7	0.0282
SQF 7-4	927	101	Rp 1 1/2	11.0	11.0	0.0282
SQF 7-4 N	927	101	Rp 1 1/2	12.5	12.5	0.0282
SQF9-3	1011	101	Rp 2	10.6	12.1	0.0282
SQF 9-3 N	1011	101	Rp 2	10.6	12.1	0.0282
SQF 14-3	982	101	Rp 2	11.2	12.7	0.0282
SQF 14-3 N	982	101	Rp 2	11.2	12.7	0.0282

* Pump complete

Electrical data

30-300 VDC or 1 x 90-240 VAC, 50/60 Hz

Pump type	Motor type	Maximum power input P1 [W]	Maximum current [A]
SQF 0.6-2 (N)	MSF 3 (N)	1400	8.4
SQF 0.6-3 (N)	MSF 3 (N)	1400	8.4
SQF 1-8 (N)	MSF 3 (N)	300	8.4
SQF 1.2-2 (N)	MSF 3 (N)	1400	8.4
SQF 1.2-3 (N)	MSF 3 (N)	1400	8.4
SQF 2.5-2 (N)	MSF 3 (N)	1400	8.4
SQF 3A-10 (N)	MSF 3 (N)	1400	8.4
SQF 5A-3 (N)	MSF 3 (N)	1400	8.4
SQF 5A-7 (N)	MSF 3 (N)	1400	8.4
SQF 7-4 (N)	MSF 3 (N)	1400	8.4
SQF 9-3 (N)	MSF 3 (N)	1400	8.4
SQF 14-3 (N)	MSF 3 (N)	1400	8.4

SQF pump

Power supply to pump	30-300 VDC, PE. 1 x 90-240 V - 10 %/+ 6 %, 50/60 Hz, PE.
Power consumption	Maximum 300 W or 1400 W.
Current consumption	Maximum 8.4 A.
Run-up time	Depends on the energy source.
Start/stop	No limitation to the number of starts/stops per hour.
Enclosure class	IP68.
Motor protection	Built into the pump. Protection against <ul style="list-style-type: none"> • dry running by means of a water level electrode • overvoltage and undervoltage • overload • overtemperature.
Conductivity	≥ 70 µs/cm (micro siemens).
Sound pressure level	The sound pressure level of the pump is lower than the limiting values stated in the EC Machinery Directive.
Radio noise	The SQF complies with the EMC Directive 89/336/EEC. Tested according to the standards EN 61000-6-2 and EN 61000-6-3.
Reset function	The SQF can be reset via the CU 200 or by disconnecting the power supply for 1 minute.
Power factor	PF = 1.
Operation via generator	Voltage: 230 VAC - 10 %/+ 6 %. The generator output must be minimum 1.55 kVA.
Earth-leakage circuit breaker	If the pump is connected to an electric installation where an earth-leakage circuit breaker (ELCB) is used as an additional protection, this circuit breaker must trip out when earth fault currents with DC content (pulsating DC) occur.
Borehole diameter	SQF 0.6, SQF 1, SQF 1.2, SQF 2.5: Minimum: 76 mm. SQF 3A, SQF 5A, SQF 7, SQF 9, SQF 14. Minimum: 104 mm.
Installation depth	Minimum: The pump must be completely submerged in the pumped liquid. Maximum: 150 m below the static water table (15 bar).
Suction strainer	Holes of the suction strainer: SQF 0.6 (N), SQF 1 (N), SQF 1.2 (N), SQF 2.5 (N): Ø2.3. SQF 3A (N), SQF 5A: Ø2.5. SQF 5A N, SQF 8A (N), SQF 11A (N): 4 x 20 mm.
Pumped liquids	pH 5 to 9. Sand content up to 50 g/m ³ .
Marking	CE.

CU 200 SQFlex control unit

Voltage	30-300 VDC, 8.4 A. 90-240 VAC, 8.4 A.
Power consumption	5 W.
Current consumption	Maximum 130 mA.
Pump cable	Maximum length between the CU 200 and the pump: 300 m. Maximum length between the CU 200 and the level switch: 500 m.
Backup fuse	Maximum 10 A.
Radio noise	The CU 200 complies with the EMC Directive 89/336/EEC. Tested according to the standards EN 55014 and EN 55014-2.
Relative air humidity	95 %.
Enclosure class	IP55.
Ambient temperature	During operation: -30 °C to +50 °C. During storage: -30 °C to +60 °C.
Marking	CE.
Weight	2 kg.

CIU 273 SQFlex GRM control unit

Electrical data	
Supply voltage	24-240 VAC/VDC - 10 %/+ 15 %.
Transient overvoltage	Category II.
Frequency	0-60 Hz.
Power consumption	Maximum 11 W.
Cable size	IEC: 0.2 - 4 mm ² . UL: 24-12 AWG.
Recommended cable type	Screened, double twisted-pair. Cross-section: 0.25 - 1 mm ² . AWG: 24-18. Maximum cable length: 1200 m / 4000 feet.
Cable entry	6 x M16 Ø4-10.
GENIbus connection	
Transceiver	RS-485.
Protocol	GENIbus.
Transmission speed	9600 bits/s.
Environmental conditions	
Altitude above sea level	Maximum 2000 m.
Relative air humidity	Maximum 100 %.
External pollution degree	Category 3.
Enclosure class	IP54 according to IEC 60529. Type 3R according to UL 50.
Ambient temperature	
• During operation	
– CIU XXX	• -20 °C to +45 °C (-4 °F to +113 °F).
– CIU 250-299	• 0 °C to +40 °C (32 °F to +104 °F) (when battery is installed).
• During storage	
– CIU XXX	• -20 °C to +60 °C (-4 °F to +140 °F).
– CIU 250-299	• -20 °C to +35 °C (-4 °F to +95 °F) (when battery is installed).
• During transportation	
– CIU XXX	• -20 °C to +60 °C (-4 °F to +140 °F).
– CIU 250-299	• -20 °C to +35 °C (-4 °F to +95 °F) (when battery is installed).

IO 50 SQFlex switch box

Voltage	Maximum 300 VDC, 8.4 A. Maximum 265 VAC, 8.4 A.
Enclosure class	IP55.
Ambient temperature	During operation: -30 °C to +50 °C. During storage: -30 °C to +60 °C.
Marking	CE.

IO 101 SQFlex switch box

Voltage	230 VAC - 15 %/+ 10 %, 50/60 Hz (internal relay). Maximum 225 VDC, 8.4 A. Maximum 255 VAC, 8.4 A.
Voltage	115 VAC - 15 %/+ 10 %, 50/60 Hz (internal relay). Maximum 225 VDC, 8.4 A. Maximum 125 VAC, 8.4 A.
Enclosure class	IP55.
Ambient temperature	During operation: -30 °C to +50 °C. During storage: -30 °C to +60 °C.
Marking	CE.

IO 102 SQFlex breaker box

Voltage	Maximum 225 VDC, 8.4 A. Maximum 265 VAC, 8.4 A.
Enclosure class	IP55.
Ambient temperature	During operation: -30 °C to +50 °C. During storage: -30 °C to +60 °C.
Marking	CE.

Charge controller

Voltage (solar input)	Maximum 110 VDC.
Current (solar input)	Maximum 15 A.
Output current (load)	Maximum 15 A.
Ambient temperature	-40 °C to +60 °C.
Weight	0.34 kg.

Material specification, helical rotor pump

Pos.	Component	Material	SQF		SQF-N	
			EN/ DIN	AISI	EN/ DIN	AISI
1	Valve casing	Polyamide				
1a	Discharge chamber	Stainless steel	1.4301	304	1.4401	316
1d	O-ring	NBR				
2	Valve cup	Polyamide				
3	Valve seat	Silicone (LSR)				
6	Flange, upper	Stainless steel	1.4401	316	1.4401	316
7a	Retaining ring	Stainless spring steel	1.4301	304	1.4401	316
9	Pump stator	Stainless steel/EPDM	1.4301	304	1.4401	316
13	Pump rotor	Stainless steel	1.4401	316	1.4401	316
16	Torsion shaft	Stainless steel	1.4401	316	1.4401	316
39	Valve spring	Stainless spring steel	1.4310	310	1.4401	316
55	Sleeve	Stainless steel	1.4301	304	1.4401	316
70	Valve guide	Polyamide				
159c	Sand slinger	NBR				
	Cable guard	Stainless steel	1.4301	304	1.4401	316
	Screws for cable guard	Stainless steel	1.4401	316	1.4401	316

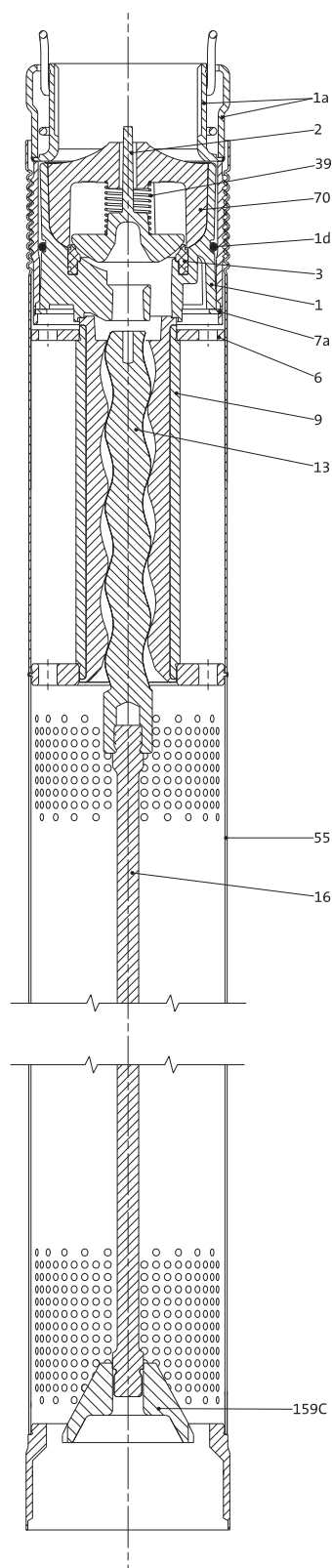

Fig. 29 Example: SQF 1.2-2

TM02 2213 2712

Material specification (SQF 1)

Pos.	Component	Material	SQF		SQF-N	
			EN/DIN	AISI	EN/DIN	AISI
1	Valve casing	Polyamide				
1a	Discharge chamber	Stainless steel	1.4301	304	1.4401	316
1d	O-ring	NBR rubber				
2	Valve cup	Polyamide				
3	Valve seat	NBR rubber				
4a	Empty chamber	Polyamide				
6	Top bearing	NBR rubber				
7	Neck ring	TPU/PBT				
7a	Lock ring	Stainless spring steel	1.4310	310	1.4404	316
7b	Neck ring retainer	Polyamide				
9b	Chamber top	Polyamide				
9c	Chamber bottom	Polyamide				
13	Impeller with tungsten carbide bearing	Polyamide				
14	Suction interconnector	Polyamide				
14a	Ring	Stainless steel	1.4301	304	1.4401	316
16	Shaft with coupling	Stainless steel / Sintered steel	1.4301	304	1.4401	316
18	Cable guard	Stainless steel	1.4301	304	1.4401	316
18a	Screws for cable guard	Stainless steel	1.4401	316	1.4401	316
30	Cone for pressure equalisation	Polyamide				
32	Guide vanes	Polyamide				
39	Spring	Stainless spring steel	1.4406	316LN	1.4406	316LN
55	Pump sleeve	Stainless steel	1.4301	304	1.4401	316
64	Priming screw	Polyamide				
70	Valve guide	Polyamide				
86	Lip seal ring	NBR rubber				
87	Cone for pressure equalisation complete	Polyamide / NBR rubber				

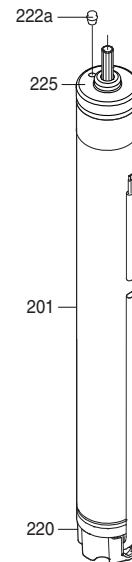
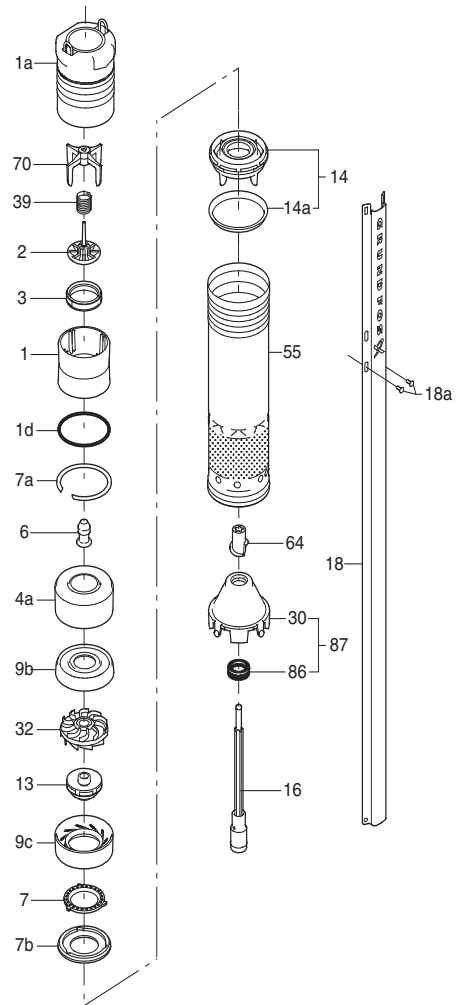

Fig. 30 Example SQF 1-8

TM01 2745 0706

Material specification (SQF 3A, SQF 5A)

Pos.	Component	Material	Standard	N-version	R-version
			EN		
1	Valve casing	Stainless steel	1.4301	1.4401	1.4539
2	Valve cup	Stainless steel	1.4301	1.4401	1.4539
3	Valve seat	Rubber type	NBR	NBR-FKM	NBR-FKM
7	Neck ring	NBR/TPU			
8	Bearing	NBR			
	Washer for stop ring	Carbon/graphite HY22 in PTFE mass			
9	Chamber	Stainless steel	1.4301	1.4401	1.4539
12	Impeller	Stainless steel	1.4301	1.4401	1.4539
14	Suction interconnector	Cast stainless steel	1.4308	1.4408	1.4517
	Strainer	Stainless steel	1.4301	1.4401	1.4539
16	Shaft complete	Stainless steel	1.4057	1.4460	1.4462
17	Strap	Stainless steel	1.4301	1.4401	1.4539
18	Cable guard	Stainless steel	1.4301	1.4401	1.4539

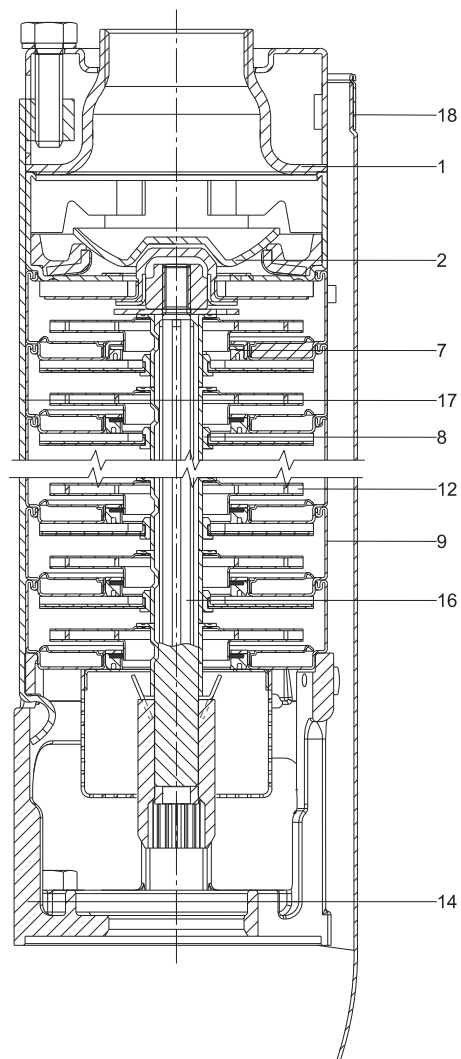

Fig. 31 Example SQF 3, pump with spline shaft

TM06 1193 1614

Material specification (SQF 7, SQF 9, SQF 14)

Pos.	Component	Material	EN		
			Standard	N-version	R-version
1	Valve casing	Cast stainless steel	1.4301	1.4401	1.4539
2	Valve cup	Cast stainless steel	1.4301	1.4401	1.4539
3	Valve seat	NBR-FKM	NBR-FKM	NBR-FKM	NBR-FKM
7	Neck ring	TPU/PPS-FKM	TPU/PPS-FKM	TPU/PPS-FKM	TPU/PPS-FKM
8	Bearing	LSR/FKM	LSR/FKM	LSR/FKM	LSR/FKM
8a	Washer for stop ring	Carbon/graphite HY22 in PTFE mass			
9	Chamber	Stainless steel	1.4301	1.4401	1.4539
13	Impeller	Stainless steel	1.4301	1.4401	1.4539
14	Suction interconnector	Cast stainless steel	1.4308	1.4408	1.4517
15	Strainer	Stainless steel	1.4301	1.4401	1.4539
16	Shaft complete	Stainless steel	1.4057	1.4460	1.4462
17	Strap	Stainless steel	1.4301	1.4401	1.4539
18	Cable guard	Stainless steel	1.4301	1.4401	1.4539

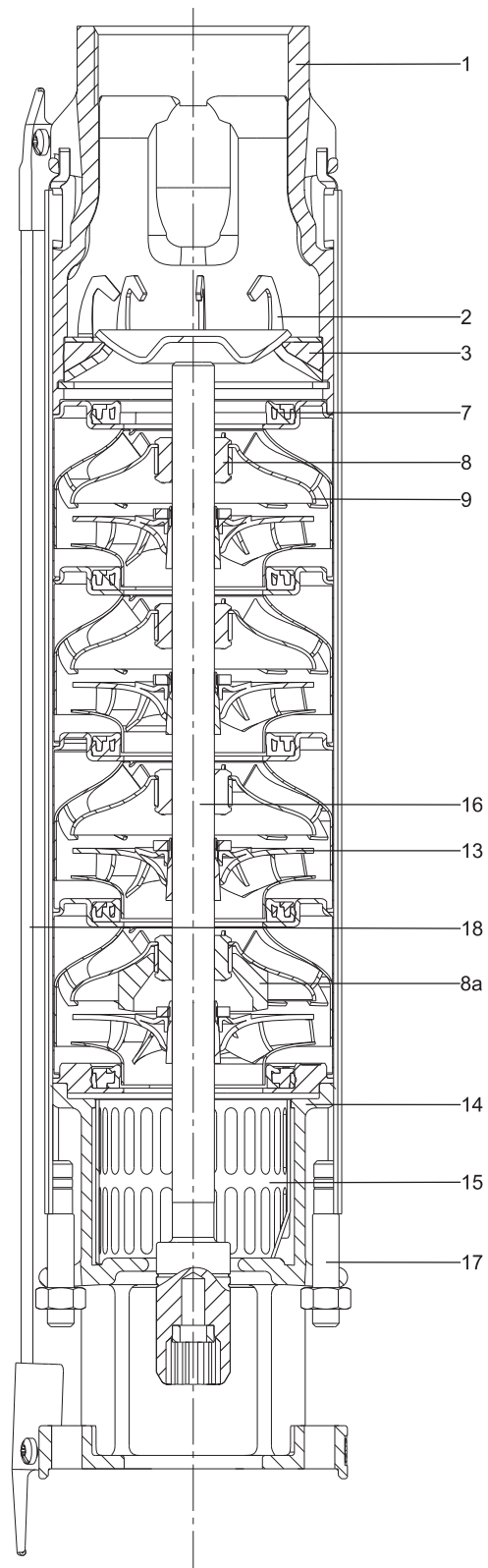

Fig. 32 Example SQF 9

TM06 1110 1614

Material specification, motor

Pos.	Component	Material	MSF 3		MSF 3 N	
			EN/DIN	AISI	EN/DIN	AISI
201	Stator with sleeve, complete	Stainless steel	1.4301	304	1.4401	316
202	Rotor	Stainless steel	1.4301	304	1.4401	316
202a	Stop ring	PP				
202c	Shaft end	Stainless steel	1.4401	316	1.4401	316
203	Thrust bearing, stationary	Stainless steel/carbon	1.4401	316	1.4401	316
205	Bearing plate with radial bearing	Silicon carbide	1.4301	304	1.4401	316
206	Thrust bearing, rotating	Stainless steel/ aluminium oxide Al_2O_3	1.4401	316	1.4401	316
220	Motor cable with plug					
222a	Filling plug	Silicone (LSR)				
223	Electronic unit					
224	O-ring	NBR				
225	Top cover	PPS				
232	Shaft seal	NBR				
243	Thrust-bearing housing	Stainless steel	1.4408	316	1.4408	316
	Four screws (M4)	Stainless steel	1.4401	316	1.4401	316

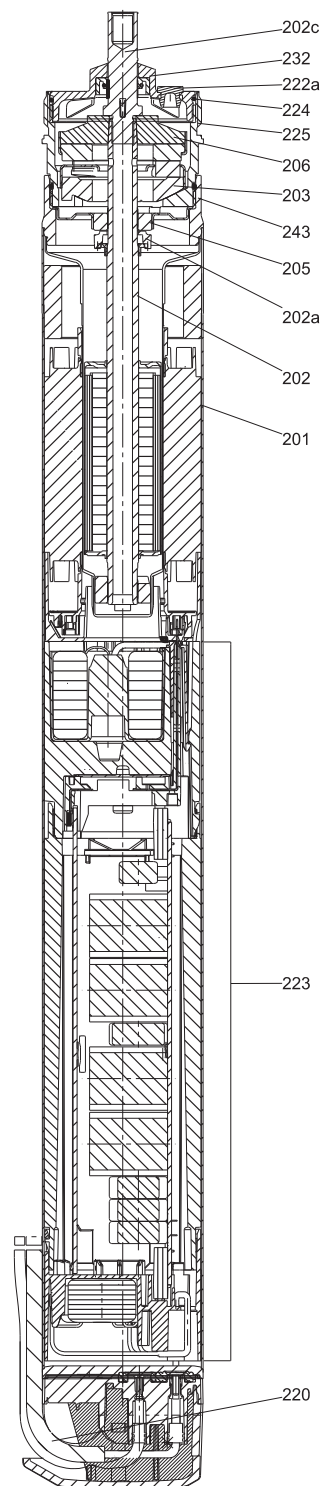
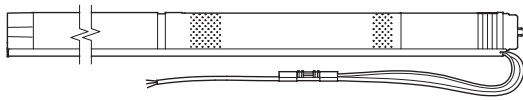

Fig. 33 MSF 3

TM02 2215 2911

8. Product numbers

SQF submersible pump



TM02 2217 3901

Fig. 34 SQF pump

The SQF pump complete is supplied with 2 m cable.

Pump type	Pump size	Product number	
		SQF	SQF-N
SQF 0.6-2 (N)	3"	95027324	95027325
SQF 0.6-3 (N)	3"	95027326	95027327
SQF 1-8 (N)	3"	98842452	98842517
SQF 1.2-2 (N)	3"	95027328	95027329
SQF 1.2-3 (N)	3"	96834838	96834839
SQF 2.5-2 (N)	3"	95027330	95027331
SQF 3A-10 (N)	4"	95027336	95027337
SQF 5A-3 (N)	4"	95027338	95027339
SQF 5A-7 (N)	4"	95027342	95027343
SQF 7-4(N)	4"	98979253	98994902
SQF 9-3 (N)	4"	98978826	98994640
SQF 14-3 (N)	4"	98979255	98994933

CU 200 SQFlex control unit

Product	Product number
CU 200 SQFlex	96625360
CU 200 SQFlex without angle plate	98147203

CIU 273 SQFlex GRM control unit

Product	Product number
CIU 273 SQFlex	97980341
CIU 903 SQFlex without GRM	98106399
CIM 500 GRM ethernet	98301408
Antenna, roof mounting, complete	97631956
Antenna, desk mounting, complete	97631957

IO 50 SQFlex switch box

Product	Product number
IO 50 SQFlex, metric	97907253
IO 50 SQFlex, US	96959028

IO 101 SQFlex switch box

Product	Product number
IO 101 SQFlex, 230 V	96475074
IO 101 SQFlex, 115 V	96481502

IO 102 SQFlex breaker box

Product	Product number
IO 102 SQFlex for wind turbine	96475065

Charge controller

Product	Product number
Charge controller	96023194

Submersible drop cables

The submersible drop cables for SQF pumps are approved for use with potable water (KTW-approved). The cables are made of EPR (ethylene-propylene rubber).

Sizing of cable

Use the following formula:

$$L = \frac{\Delta P \times q \times V_{mp}^2}{W_p \times 100 \times 2 \times \rho} [m]$$

L = length of cable [m]

ΔP = power loss [%]

q = cross-section of submersible drop cable [mm²]

V_{mp} = maximum power voltage [V]

W_p = Watt peak [Wp]

ρ = specific resistance: 0.0173 [Ω mm²/m].

See [Grundfos Product Center](#) on page 47. The sizing tool makes it possible to calculate the exact losses.

9. Accessories

Flow sleeve for SQFlex 3" standard version (EN 1.4301/AISI 304)

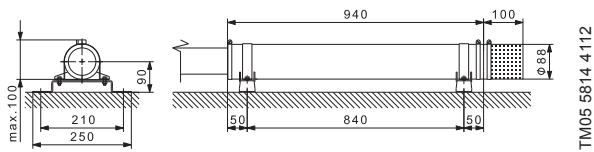

Fig. 35 SQFlex 3" flow sleeve and strainer

Product	Material	Product number
Flow sleeve complete (including strainer and supporting brackets)	Stainless steel EN 1.4301	98253259
Flow sleeve	Stainless steel EN 1.4301	98253254
Strainer	Stainless steel EN 1.4301	97943446
Supporting brackets	Stainless steel EN 1.4301	97512995

Flow sleeve for SQFlex 4" standard version (EN 1.4301/AISI 304)

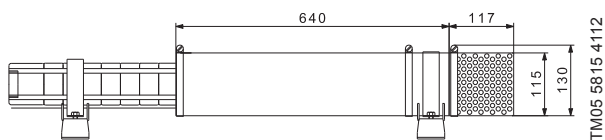

Fig. 36 SQFlex 4" flow sleeve and strainer

Product	Material	Product number
Flow sleeve complete (including strainer and supporting brackets)	Stainless steel EN 1.4301	98255476
Flow sleeve	Stainless steel EN 1.4301	98255472
Strainer	Stainless steel EN 1.4301	97942211
Supporting brackets	Stainless steel EN 1.4301	96957450

Grease

Description	Product number
Grease for lubrication of motor shaft	96037562

Level switch



TM02 2407 4201

Description	Product number
Level switch	010748

High water level: Contact is closed.
Low water level: Contact is open.

Pressure switch

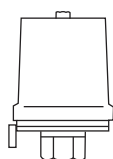

TM02 2406 1806

Description	Product number
Pressure switch	ID8952

Submersible drop cable



TM00 7882 2296

Description	Version	Diameter [mm]	Product number
3-core cable, including earth conductor. KTW-approved. When ordering, please state length [m].	3G 1.5 mm ² (round)	9.6 - 12.5	ID7946
	3G 2.5 mm ² (round)	11.5 - 14.5	ID7947
	3G 4.0 mm ² (round)	13.0 - 16.0	ID7948
	3G 6.0 mm ² (round)	14.5 - 20.0	RM4098
	3G x 1.5 mm ² (flat)	6.5 - 13.2	RM3952

Cable termination kit, type KM

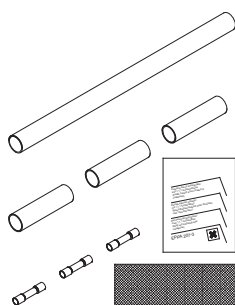

TM00 3838 1294

Description	Cross-section of conductors [mm ²]	Product number
For watertight shrink-joining of motor cable and submersible drop cable (round or flat cable). Enables the joining of • cables of equal size • cables of different size • cable with single leads.	1.5 - 6.0	96021473
The joint is ready for use after a few minutes and requires no long hardening time as do resin joints.		
The joint cannot be separated.		

Cable clips



TM00 7897 2296

Description	Dimensions [m]	Product number
For fastening of cable and straining wire to the riser pipe. The clips should be fitted every 3 metres. One set for approx. 45 m riser pipe.	Length: 7.5 16 buttons	115016

Straining wire



TM00 7897 2296

Description	Diameter [mm]	Product number
Stainless steel DIN W.-Nr. 1.4401. Retains the submersible pump. When ordering, please state length [m].	2	ID8957

Wire clamp



TM00 7898 2296

Description	Material	Product number
Two clamps per loop	Stainless steel DIN W.-Nr. 1.4401	ID8960

Zinc anodes

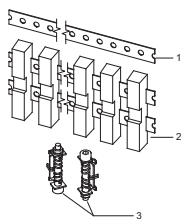

TM01 4430 0199

Description	Product number
For additional protection, e.g. if the Cl ⁻ content exceeds 500 ppm, zinc anodes can be used. Sacrificial anodes are placed on the outside of the pump and motor as protection against corrosion. The number of anodes required depends on the pump and motor in question. Product number includes: 2 x 6 anodes with clips. Diameter when fitted: 125 mm. Minimum borehole diameter: 127 mm (5").	97645697

Solar cables

Description	Version	Length [m]	Product number
DC cable (12 AWG/3, 3 mm ²), UL-approved, for outdoor use. Select connector type MC3 or MC4.	Array to controller (MC3)	10	91126024
	Array to array (MC3)	0.5	91126023
	Array to controller (MC4)	10	98257868
	Array to array (MC4)	0.5	98257892

10. Grundfos Product Center

Online search and sizing tool to help you make the right choice.

<http://product-selection.grundfos.com>



"SIZING" enables you to size a pump based on entered data and selection choices.

"REPLACEMENT" enables you to find a replacement product. Search results will include information on the following:

- the lowest purchase price
- the lowest energy consumption
- the lowest total life cycle cost.

The screenshot shows the Grundfos Product Center website. At the top, there is a navigation bar with the logo and 'PRODUCT CENTER'. Below it is a search bar with a 'SEARCH' button. A main menu contains four categories: 'SIZING' (Enter pump sizing), 'CATALOGUE' (Products and services), 'REPLACEMENT' (Replace an old pump with a new), and 'LIQUIDS' (Find pump by liquid). The 'QUICK SIZING' section is visible, featuring input fields for 'Flow (Q)*' and 'Head (H)*', and radio buttons for 'Select what to size by: Size by application', 'Size by pump design', and 'Size by pump family'. A 'START SIZING' button is also present.

"CATALOGUE" gives you access to the Grundfos product catalogue.

"LIQUIDS" enables you to find pumps designed for aggressive, flammable or other special liquids.

All the information you need in one place

Performance curves, technical specifications, pictures, dimensional drawings, motor curves, wiring diagrams, spare parts, service kits, 3D drawings, documents, system parts. The Product Center displays any recent and saved items - including complete projects - right on the main page.

Downloads

On the product pages, you can download installation and operating instructions, data booklets, service instructions, etc. in PDF format.

Subject to alterations.

96477803 0917

ECM: 1217081

GRUNDFOS A/S
DK-8850 Bjerringbro . Denmark
Telephone: +45 87 50 14 00
www.grundfos.com

GRUNDFOS 