

S A W Africa

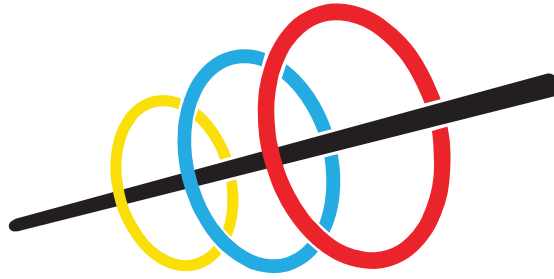

knowledge product success



Motors

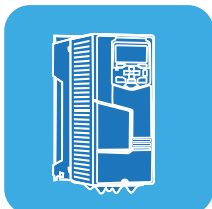

VSD's



Pumps



Gearboxes



Service



Renewables

Table of contents

Overview	3
Standard Features	3
Nameplate	4
Mechanical Design	4
Cooling and Ventilation	4
Bearings	5
General Specifications	5
Insulation	5
Temperature Rise	6
Electrical Design	7
Performance Data	8
Contact Details	16

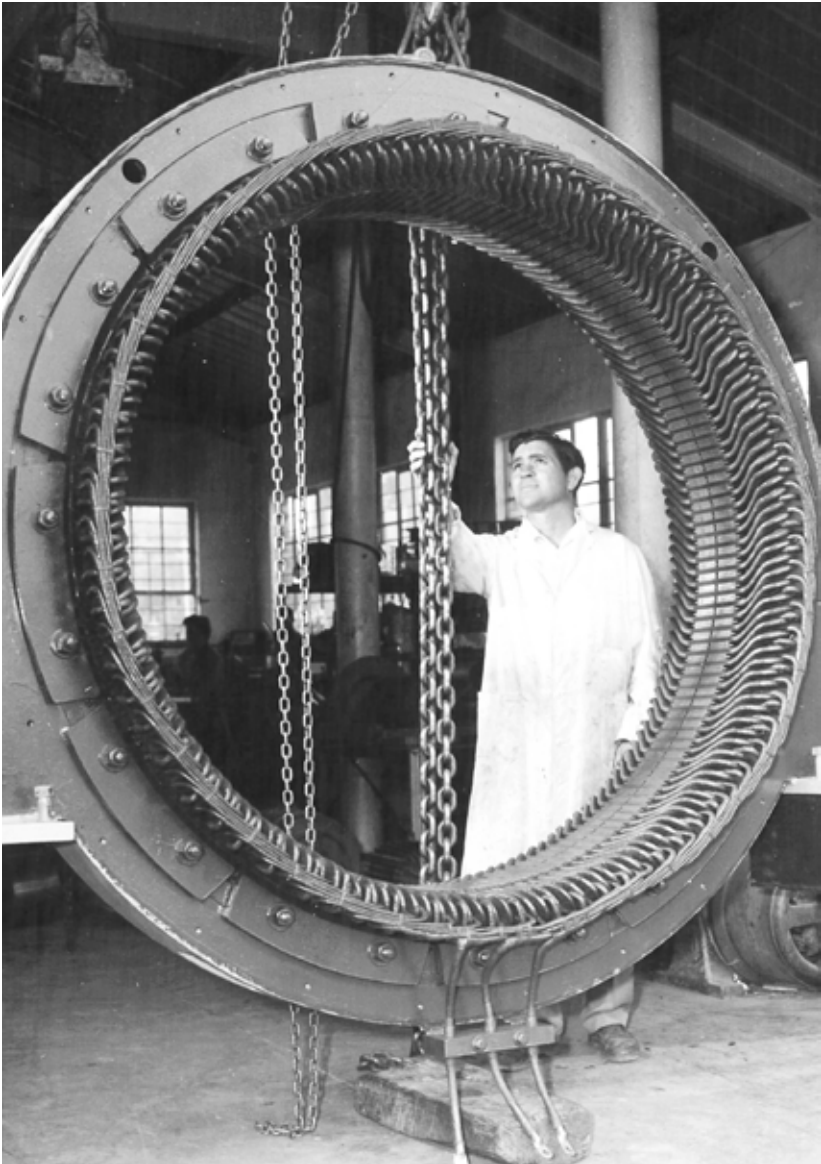

Overview

The IE2 series of 3 phase asynchronous motors are Totally Enclosed Fan Cooled (TEFC) with IP55 environmental protection. These motors are designed and manufactured in accordance with IEC standards, by Hengsu Holdings for S A W Africa.

Standard Features

- Frame material: Cast Iron
- Terminal box material: Cast Iron
- Plastic cable glands is standard (Metallic cable glands is optional)
- Standard color: RAL 5010
- Specific wound stators supporting multiple 3PH mains supply voltages at 50Hz or 60Hz
- Cast Iron Frame sizes: 80mm - 355mm
- Rated power range: 0.09kW - 355kW at 50Hz
- Standard mounting types and variations (IEC 60034-7)
- Overload capacity of 1.5 times rated current for 2 minutes(IEC 60034-1)
- All Electric motor are protected to IP55 as a minimum, higher levels of protection are available on request.
- Oil seal as standard on DE and NDE
- Winding protection with PTC, PT130 or PT150 as option
- Insulation class: F, used according to temperature rise B
- Flexible cable entry (Rotatable terminal box)
- Shaft extension with open or closed keyway
- Regreasable from frame size 160 and up
- Anti-condensation heater as option
- Brakes as option
- Forced cooling as option
- Roller bearings as option
- Angular contact bearing as option
- PT100 sensors on windings and bearings as option
- Colour change C2 to C5 corrosion protections as option

The IE2 is a general purpose motor with cast iron frame designed for constant or adjustable speed with continuous duty operation (S1) torque over a speed range.

Load Torque Characteristics

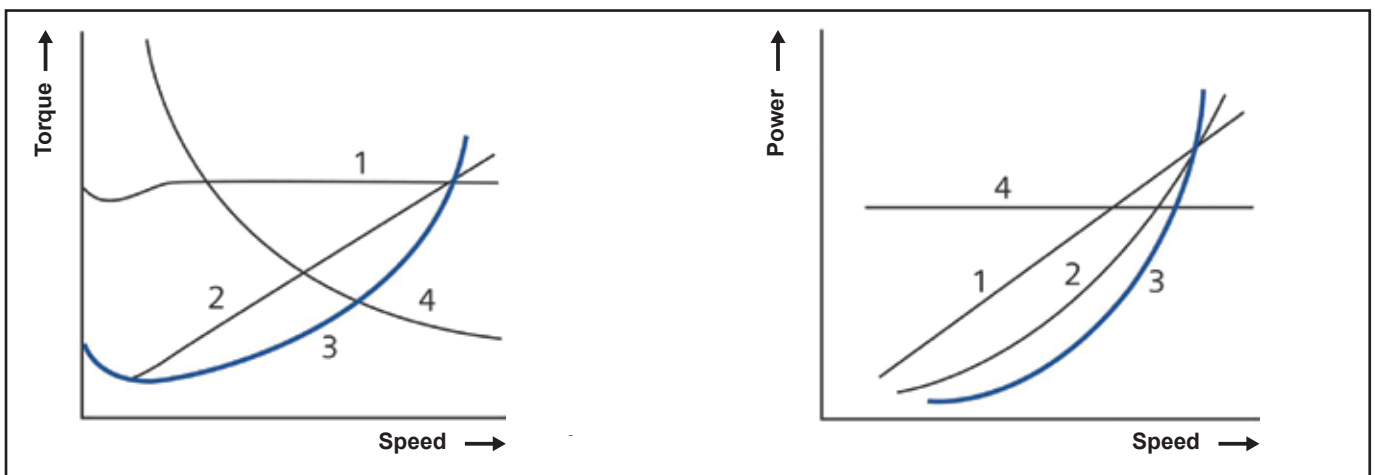

Torque / Speed Characteristic

Power / Speed Characteristic

1. Torque almost constant; power proportional to speed.
2. Torque increases proportionally with the speed; power proportional to the square of the speed.
3. Torque increases proportionally with the square of the speed; power proportional to the cube of the speed.
4. Torque decreases in inverse proportion to the speed; power constant.

Nameplate

Motor type
 Duty cycle
 Serial nr
 Drive End bearing & Non Drive End bearing
 Protection degree
 Weight
 Insulation class
 Rated voltage
 Rated frequency
 RPM
 Rated output
 Electric current
 Power factor

S A W Africa			IEC 60034-1			
TYPE	IE2-160M-4	No. 01190463-390714			B3	
6309/C3 DE	6309/C3 NDE	Ins.cl.F	IP 55			
V	Hz	kW	r/min	A	cosφ	duty
380DELTA	50	11	1470	22.2	0.84	S1
660STAR	50	11	1470	12.8	0.84	S1
50Hz-IE2:89.5(100%)-89.8(75%)-88.0(50%)						
S1-100%	Amb: 40°C	Alt: 1000m		108kg		

Mechanical Design

Terminal Box

Terminal boxes are top mounted as default on the motor. The box can be rotated by 4 X 90° to allow for cable entry from each direction. In addition the terminal box can be installed either on the Left Hand Side or Right Hand Side when viewed from the drive end (DE) side of the motor.

Motor Type	Frame Size	Protection Degree	Rotation of Terminal Box	Number of Cable Gland	Terminal Box Material	Terminal Bus	Max Cable Size (mm ²)	Cable Entry Size
IE2	63	IP55	4x90°	1	Aluminum	M4	2	M18x1.5
	71	IP55	4x90°	1	Aluminum	M4	2	M18x1.5
	80	IP55	4x90°	1	Aluminum	M4	2.5	M20x1.5
	90	IP55	4x90°	1	Aluminum	M5	2.5	M20x1.5
	100	IP55	4x90°	1	Aluminum	M5	4	M25x1.5
	112	IP55	4x90°	1 or 2	Aluminum	M5	4	M27x1.5
	132	IP55	4x90°	1 or 2	Aluminum	M5	6	M27x1.5
	160	IP55	4x90°	2	Cast-iron	M6	10	2-M32x1.5
	180	IP55	4x90°	2	Cast-iron	M6	16	2-M32x1.5
	200	IP55	4x90°	2	Cast-iron	M8	25	2-M40x1.5
	225	IP55	4x90°	2	Cast-iron	M8	35	2-M40x1.5
	250	IP55	4x90°	2	Cast-iron	M10	120	2-M50x1.5
	280	IP55	4x90°	2	Cast-iron	M10	120	2-M50x1.5
	315	IP55	4x90°	2	Cast-iron	M16	240	2-M63x1.5
	355	IP55	4x90°	2	Cast-iron	M20	400	2-M72x2

Cooling and Ventilation

The standard motors from FS 80 - 355 are fitted with a radial flow fan for cooling in accordance with IEC 60034-6 cooling methods. For applications where self ventilation is not adequate, an optional external cooling fan can be ordered.

Bearings

All motors are supplied with ball bearings as standard. FS 160 and above, roller bearings and angular contact ball bearings as options.

Bearing type

Motor type	Frame size	Poles	Drive End bearing	Non Drive End bearing
IE2	63	2,4	6201 2RZC3	6201 2RZC3
IE2	71	2,4	6202 2RZC3	6202 2RZC3
IE2	80	2,4	6204 2RZC3	6204 2RZC3
IE2	90	2,4	6205 2RZC3	6205 2RZC3
IE2	100	2,4	6206 2RZC3	6206 2RZC3
IE2	112	2,4	6206 2RZC3	6206 2RZC3
IE2	132	2,4	6208 2RZC3	6208 2RZC3
IE2	160	2,4	6309 C3	6309 C3
IE2	180	2,4	6311 C3	6311 C3
IE2	200	2,4	6312 C3	6312 C3
IE2	225	2,4	6313 C3	6313 C3
IE2	250	2,4	6314 C3	6314 C3
IE2	280	2	6314 C3	6314 C3
IE2	280	4	6317 C3	6317 C3
IE2	315	2	6317 C3	6317 C3
IE2	315	4	6319 C3	6319 C3
IE2	355	2	6319 C3	6319 C3
IE2	355	4	6322 C3	6322 C3

General Specifications

Voltages / Frequencies

Standard Voltages are 380v-420 50Hz and 440-480 60Hz

Insulation

The components of the insulation system are selected so as to ensure good protection against chemically aggressive gases, vapours, dust, oil and air humidity.

All materials used for insulating the winding and winding ends correspond to insulating classes F or H according to IEC 60085:

- -Enamel-insulated copper wires with temperature index 200(Class H);
- -Insulating sheet on polyester base (Class F);
- -Impregnation with fenolic resins modified with polyester resins (Class H); Limit temperature for insulating material according IEC60085

Insulation Class	Limit Temperature (°C)
B	130
F	155
H	180

Temperature Rise

Standard single-speed continuous duty (S1) motors have temperature rise within class B limit.

Insulation Class	Limit Temperature (°C)
B	80
F	105
H	125

Temperature rises specified at a reference ambient air temperature of 40°C

PTC temperature sensor (thermistors):

(Supplied on motors 11kW and above)

It consists of 3 sensors connected in series embedded in the stator winding.

Duty Cycles

S1 Continuous Duty	Operation under constant load lasting long enough to allow the machine to reach thermal equilibrium.
S2 Short-Time Duty	Operation under constant load for a time too short to allow the machine to reach thermal equilibrium. Idle time of the machine is long enough to allow the machine to cooldown to ambient temperature. Standard duration of short-term operation: 10, 30, 60 and 90 minutes.
S3 Intermittent Periodic Duty	Operation under repeated constant load in specified cycles. Neither operating nor resting period are long enough to allow the motor to reach thermal equilibrium. The starting losses are small and do not essentially influence the temperature rise. The nominal values of relative starting time are 15, 25, 40, 60% at a daily 10-minute cycle.
S4 Intermittent Periodic Duty	Operation under repeated constant load in specified cycles. The start of the motor influences the temperature rise.
S5 Intermittent Periodic Duty	Same as S4 operation except that the electric braking of the machine has an essential influence on the temperature rise.
S6 Continuously Operation With Cyclic Load	Operation consisting of a continuous series of equal cycles. Each cycle is made up of no load and a constant load period. The cycle duration is not long enough to allow the machine to reach thermal equilibrium in one cycle. In order to define S6 operation, the relative starting time must be specified.
S7 Intermittent Periodic Duty with Starting and Braking	Uninterrupted operation with a series of constant loading and braking periods. The most demanding type of operation for the motor. In order to define this type of operation the number of cycles per hour and the inertia constant must be specified.
S2 Intermittent Periodic Duty with pole Changing	This type of operation only exists with pole amplitude modulated motors. In this case the definition of operation must contain the following data for each pole: <ul style="list-style-type: none"> - Number of starts per hour - Inertia constant - Relative operation period

Electrical Design

Reliable Quality and Performance

To ensure reliable and long life, the windings are made of materials with class F temperature rise limited to class B (80K).

Voltage and Frequency

Standard motor will operate on mains power supplies in accordance with IEC 60034-1 Category A (combination of voltage deviation $\pm 5\%$ and frequency deviation $\pm 2\%$) voltage and frequency fluctuations.

Rated Output

Rated output power refers to continuous duty (S1) operation in accordance with IEC 60034-1 when operated at 40°C ambient temperature and at site altitudes of 1000m or less. Current overload is in accordance with IEC 60034-1(1.5 times for 2 minutes).

Environmental

- Suitable for IP55 installations
- Below or equal to 1000m above sea level
- Operating temperature between -20°C and 40°C
- Relative humidity

Temperature	Relative Humidity
-20°C ≤ T ≤ 20°C	100%
20°C ≤ T ≤ 30°C	95%
30°C ≤ T ≤ 40°C	55%

Note: For other requirements S A W Africa should be consulted.

If environmental conditions vary from those listed above, please consult the chart below for output power derating factor.

	< 30°C	30~40°C	45°C	50°C	55°C	60°C
1000m	1.07	1.00	0.96	0.92	0.87	0.82
1500m	1.04	0.97	0.93	0.89	0.84	0.79
2000m	1.00	0.94	0.90	0.86	0.82	0.77
2500m	0.96	0.90	0.86	0.83	0.78	0.74
3000m	0.92	0.86	0.82	0.79	0.75	0.70
3500m	0.88	0.82	0.79	0.75	0.71	0.67
4000m	0.82	0.77	0.74	0.71	0.67	0.63

Space heater electrical data

Frame Size	80-90	100-112	132-160	180-200	225-280	315	355
Power (W)	20	30	40	50	60	80	110
Voltage (V)	220						

IE2 Performance Data

2 Pole

380 ~ 420V / 50Hz

440 ~ 480V / 60Hz

Synchronous speed 3000 r/min

Type No.	Rated output (kW)	HP	Related current IFL 380V A	Related current IFL 400V A	Related current IFL 420V A	Related speed (r/min)	Related current IFL 440V A	Related current IFL 460V A	Related current IFL 480V A	Related speed (r/min)	EFF %	Power factor cos φ	Rated Torque N.m	Start Torque Rated Torque TST/TFL	Start Torque Rated Torque TST/TFL	Max Torque Rated Torque TST/TFL	Noise level LW dB(A)	Weight (Kg)
IE2																		
IE2-80M1-2	0.75	1.0	1.8	1.71	1.63	2855	1.55	1.49	1.43	3425	77.4	0.82	2.51	2.2	7.0	2.3	62	16
IE2-80M2-2	1.1	1.5	2.5	2.38	2.26	2870	2.16	2.07	1.98	3440	79.6	0.83	3.66	2.2	7.3	2.3	62	17
IE2-90S-2	1.5	2.0	3.3	3.14	2.99	2865	2.85	2.73	2.61	3435	81.3	0.84	5	2.2	7.6	2.3	67	20
IE2-90L-2	2.2	3.0	4.7	4.47	4.25	2870	4.06	3.88	3.72	3440	83.2	0.85	7.32	2.2	7.6	2.3	67	23
IE2-100L-2	3	4.0	6.2	5.89	5.61	2875	5.35	5.12	4.91	3450	84.6	0.87	10	2.2	7.8	2.3	74	34
IE2-112M-2	4	5.5	8.0	7.60	7.24	2910	6.91	6.61	6.33	3490	85.8	0.88	13.1	2.2	8.3	2.3	77	42
IE2-132S1-2	5.5	7.5	10.9	10.4	9.86	2935	9.41	9.00	8.63	3520	87.0	0.88	17.9	2.0	8.3	2.3	79	62
IE2-132S2-2	7.5	10	14.5	13.8	13.1	2930	12.5	12.0	11.5	3515	88.1	0.89	24.4	2.0	7.9	2.3	79	70
IE2-160M1-2	11	15	21	20.0	19.0	2950	18.1	17.4	16.6	3540	89.4	0.89	35.6	2.0	8.1	2.3	81	112
IE2-160M2-2	15	20	28.4	27.0	25.7	2945	24.5	23.5	22.5	3530	90.3	0.89	48.6	2.0	8.1	2.3	81	120
IE2-160L-2	18.5	25	34.7	33.0	31.4	2945	30.0	28.7	27.5	3530	90.9	0.89	60	2.0	8.2	2.3	81	138
IE2-180M-2	22	30	41.1	39.1	37.2	2950	35.5	34.0	32.5	3540	91.3	0.89	71.2	2.0	8.2	2.3	83	180
IE2-200L1-2	30	40	55.7	52.9	50.4	2960	48.1	46.0	44.1	3550	92.0	0.89	96.8	2.0	7.6	2.3	84	240
IE2-200L2-2	37	50	68.3	64.9	61.8	2960	59.0	56.4	54.1	3550	92.5	0.89	119	2.0	7.6	2.3	84	260
IE2-225M-2	45	60	82.7	78.6	74.8	2965	71.4	68.3	65.5	3555	92.9	0.89	145	2.0	7.7	2.3	86	305
IE2-250M-2	55	75	101	96.0	91.4	2970	87.2	83.4	80.0	3560	93.2	0.89	177	2.0	7.1	2.3	89	386
IE2-280S-2	75	100	137	130.2	124.0	2975	118.3	113.2	108.5	3570	93.8	0.89	241	1.8	7.1	2.3	91	515
IE2-280M-2	90	120	163	154.9	147.5	2970	140.8	134.7	129.0	3560	94.1	0.89	289	1.8	7.1	2.3	91	560
IE2-315S-2	110	150	197	187.2	178.2	2975	170.1	162.7	156.0	3570	94.3	0.90	353	1.8	7.1	2.3	92	920
IE2-315M-2	132	180	236	224.2	213.5	2975	203.8	195.0	186.8	3570	94.6	0.90	424	1.8	7.1	2.3	92	1035
IE2-315L1-2	160	220	282	267.9	255.1	2975	243.6	233.0	223.3	3570	94.8	0.91	514	1.8	7.2	2.3	92	1115
IE2-315L2-2	200	270	352	334.4	318.5	2975	304.0	290.8	278.7	3570	95.0	0.91	642	1.8	7.2	2.2	92	1165
IE2-355M-2	250	340	439	417.1	397.2	2980	379.1	362.7	347.5	3575	95.0	0.91	801	1.6	7.2	2.2	100	1616
IE2-355L-2	315	430	554	526.3	501.2	2980	478.5	457.7	438.6	3575	95.0	0.91	1009	1.6	7.2	2.2	100	1806

IE2 Performance Data

4 Pole

380 ~ 420V / 50Hz

440 ~ 480V / 60Hz

Synchronous speed 1500 r/min

Type No.	Rated output (kW)	HP	Related current IFL 380V A	Related current IFL 400V A	Related current IFL 420V A	Related speed (r/min)	Related current IFL 440V A	Related current IFL 460V A	Related current IFL 480V A	Related speed (r/min)	EFF %	Power factor cos φ	Rated Torque N.m	Start Torque Rated Torque TST/TFL	Start Torque Rated Torque TST/TFL	Max Torque Rated Torque TST/TFL	Noise level LW dB(A)	Weight (Kg)
IE2																		
IE2-80M2-4	0.75	1.0	1.9	1.81	1.72	1425	1.64	1.57	1.50	1710	79.6	0.76	5.03	2.3	6.6	2.3	56	18
IE2-90S-4	1.1	1.5	2.7	2.57	2.44	1420	2.33	2.23	2.14	1700	81.4	0.77	7.4	2.3	6.8	2.3	59	21
IE2-90L-4	1.5	2.0	3.5	3.33	3.17	1420	3.02	2.89	2.77	1700	82.8	0.78	10.1	2.3	7.0	2.3	59	24
IE2-100L1-4	2.2	3.0	5	4.75	4.52	1430	4.32	4.13	3.96	1715	84.3	0.80	14.7	2.3	7.6	2.3	64	34
IE2-100L2-4	3	4.0	6.6	6.27	5.97	1430	5.70	5.45	5.23	1715	85.5	0.81	20	2.3	7.6	2.3	64	38
IE2-112M-4	4	5.5	8.7	8.27	7.87	1450	7.51	7.19	6.89	1740	86.6	0.81	26.3	2.2	7.8	2.3	65	45
IE2-132S-4	5.5	7.5	11.6	11.0	10.5	1465	10.0	9.58	9.18	1755	87.7	0.82	35.9	2.0	7.9	2.3	71	64
IE2-132M-4	7.5	10.0	15.5	14.7	14.0	1465	13.4	12.8	12.3	1755	88.7	0.83	48.9	2.0	7.5	2.3	71	78
IE2-160M-4	11	15	22.4	21.3	20.3	1470	19.4	18.5	17.7	1760	89.8	0.83	71.5	2.0	7.7	2.3	73	120
IE2-160L-4	15	20	29.9	28.4	27.1	1470	25.8	24.7	23.7	1760	90.6	0.84	97.4	2.0	7.8	2.3	73	138
IE2-180M-4	18.5	25	36.3	34.5	32.8	1470	31.4	30.0	28.7	1760	91.2	0.85	120	2.0	7.8	2.3	76	174
IE2-180L-4	22	30	42.9	40.8	38.8	1465	37.1	35.4	34.0	1755	91.6	0.85	143	2.0	7.8	2.3	76	188
IE2-200L-4	30	40	58.1	55.2	52.6	1475	50.2	48.0	46.0	1770	92.3	0.85	194	2.0	7.3	2.3	76	256
IE2-225S-4	37	50	70.5	67.0	63.8	1480	60.9	58.2	55.8	1775	92.7	0.86	239	2.0	7.4	2.3	78	300
IE2-225M-4	45	60	85.4	81.1	77.3	1480	73.8	70.6	67.6	1775	93.1	0.86	290	2.0	7.4	2.3	78	325
IE2-250M-4	55	75	104	98.8	94.1	1485	89.8	85.9	82.3	1780	93.5	0.86	354	2.0	7.4	2.3	79	400
IE2-280S-4	75	100	139	132.1	125.8	1490	120.1	114.8	110.0	1785	94.0	0.87	481	2.0	6.9	2.3	80	543
IE2-280M-4	90	120	165	156.8	149.3	1485	142.5	136.3	130.6	1780	94.2	0.88	579	2.0	6.9	2.3	80	608
IE2-315S-4	110	150	199	189.1	180.1	1485	171.9	164.4	157.5	1780	94.5	0.89	707	2.0	7.0	2.2	88	970
IE2-315M-4	132	180	238	226.1	215.3	1485	205.6	196.6	188.4	1780	94.7	0.89	849	2.0	7.0	2.2	88	1090
IE2-315L1-4	160	220	285	270.8	257.9	1485	246.1	235.4	225.6	1780	94.9	0.90	1029	2.0	7.1	2.2	88	1160
IE2-315L2-4	200	270	355	337.3	321.2	1485	306.6	293.3	281.0	1780	95.1	0.90	1286	2.0	7.1	2.2	88	1230
IE2-355M-4	250	340	444	421.8	401.7	1490	383.5	366.8	351.5	1785	95.1	0.90	1602	2.0	7.1	2.2	95	1640
IE2-355L-4	315	430	559	531.1	505.8	1490	482.8	461.8	442.5	1785	95.1	0.90	2019	2.0	7.1	2.2	95	1810

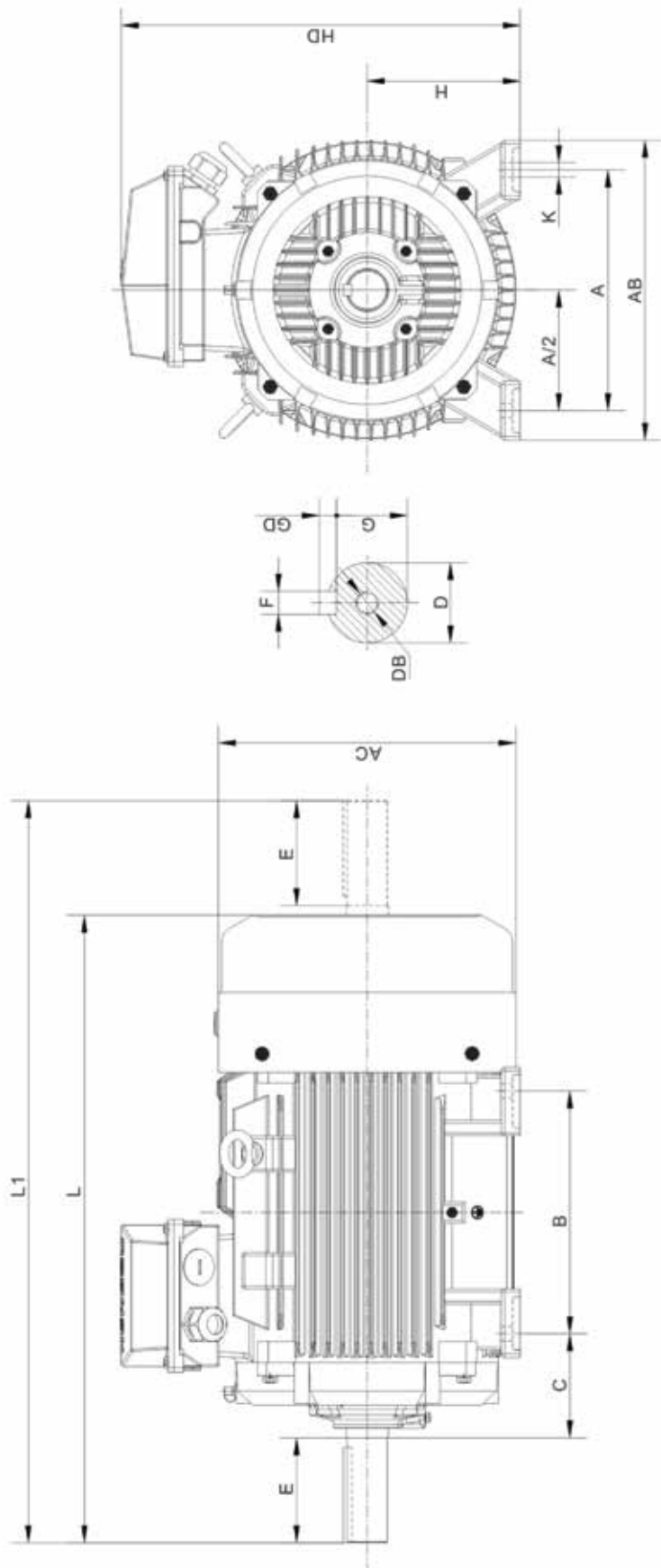

Dimensions

Frame size	Poles	A	A/2	B	C	D	E	F	G	H	K	DB	GD	AB	AC	HD	L	L1
63M	2, 4	100	50	80	40	11	+0.008	6	8.5	63	0	Φ0.5	4	135	130	180	230	255
71M	2, 4, 6	112	56	90	45	14	-0.003	8	11	71	-0.5	M4	5	150	145	195	255	290
80M		125	62.5	100	50	19	+0.009	40	15.5	80	10	M6	6	165	175	220	295	340
90S		140	70	100	56	24	-0.004	50	20	99		M8	7	180	195	250	320	375
90L				125					-0.036								345	400
100L		160	80	140	63	28		60	24	100	12	M10		205	215	270	385	450
112M		190	95	140	70					112				230	240	300	400	465
132S	2, 4, 6, 8	216	108	140	89	38	+0.018	10	33	132		M12	8	270	275	345	470	555
132M				178			+0.002										510	595
160M		254	127	210	108	42		12	37	160	15	M16		320	330	420	615	730
160L				254				14	42.5	180			9	355	380	455	700	815
180M		279	139.5	241	121	48											740	855
200L		318	159	305	133	55	+0.03	16	49	200	19	M20	10	395	420	505	770	885
225S	4, 8	356	178	286	149	60	+0.011	18	53	225			11	435	470	560	815	960
225M	2			311		55		16	49				10				820	935
	4,6,8					60		18	53				11				845	990
250M	2	406	203	349	168	65			58	250	24	Φ2.0		490	510	615	910	1055
	4,6,8																	
280S	2	457	228.5	368	190	75		20	67.5	280	0			550	580	680	985	1130
	4,6,8												12					
280M	2			419		65		18	58				11				1035	1180
	4,6,8												12					
315S	2	508	457	406	216	65		18	58	315	28			635	645	800	1160	1315
	4,6,8,10					80		22	71				14				1190	1375
315M	2			457		65		18	58				11				1270	1425
	4,6,8,10																	
315L	2			508		80		22	71				14				1300	1485
	4,6,8,10					65		18	58				11				1270	1425
355M	2	610	305	560	254	75		20	67.5	355			12	730	710	880	1500	1650
	4,6,8,10					95	+0.035	170	86				14				1530	1710
355L	2			630		75	+0.013	140	67.5				12				1500	1650
	4,6,8,10					95	+0.013	170	86				14				1530	1710
	4,6,8,10						+0.035	170										

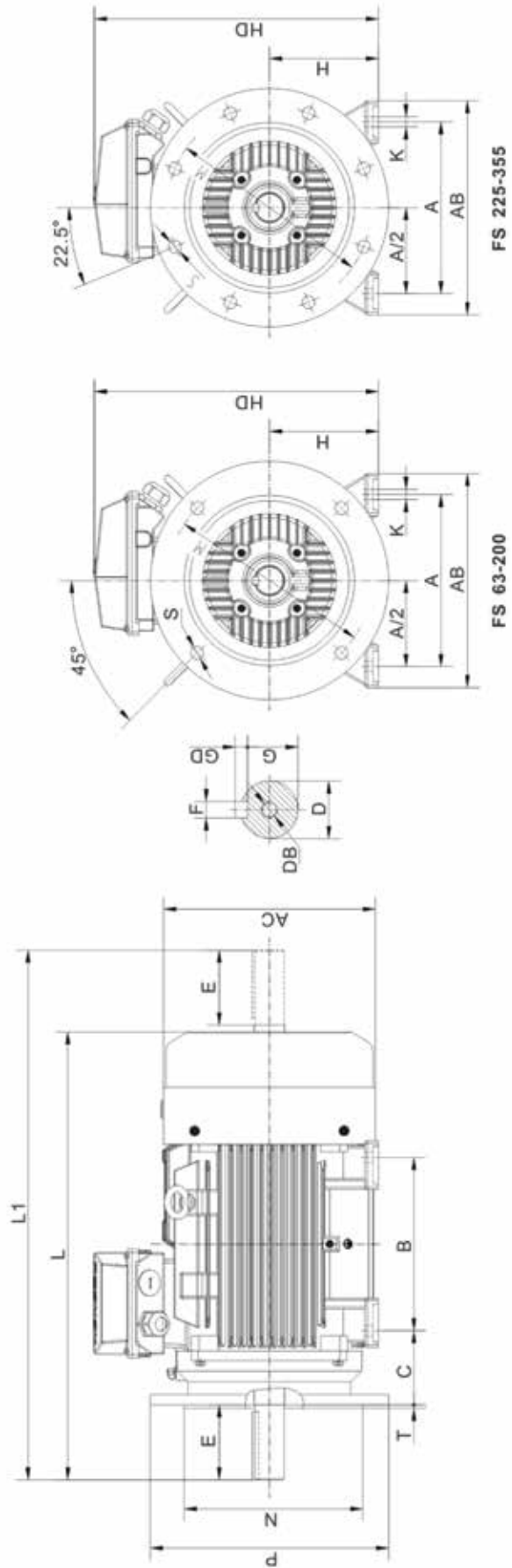

Notes

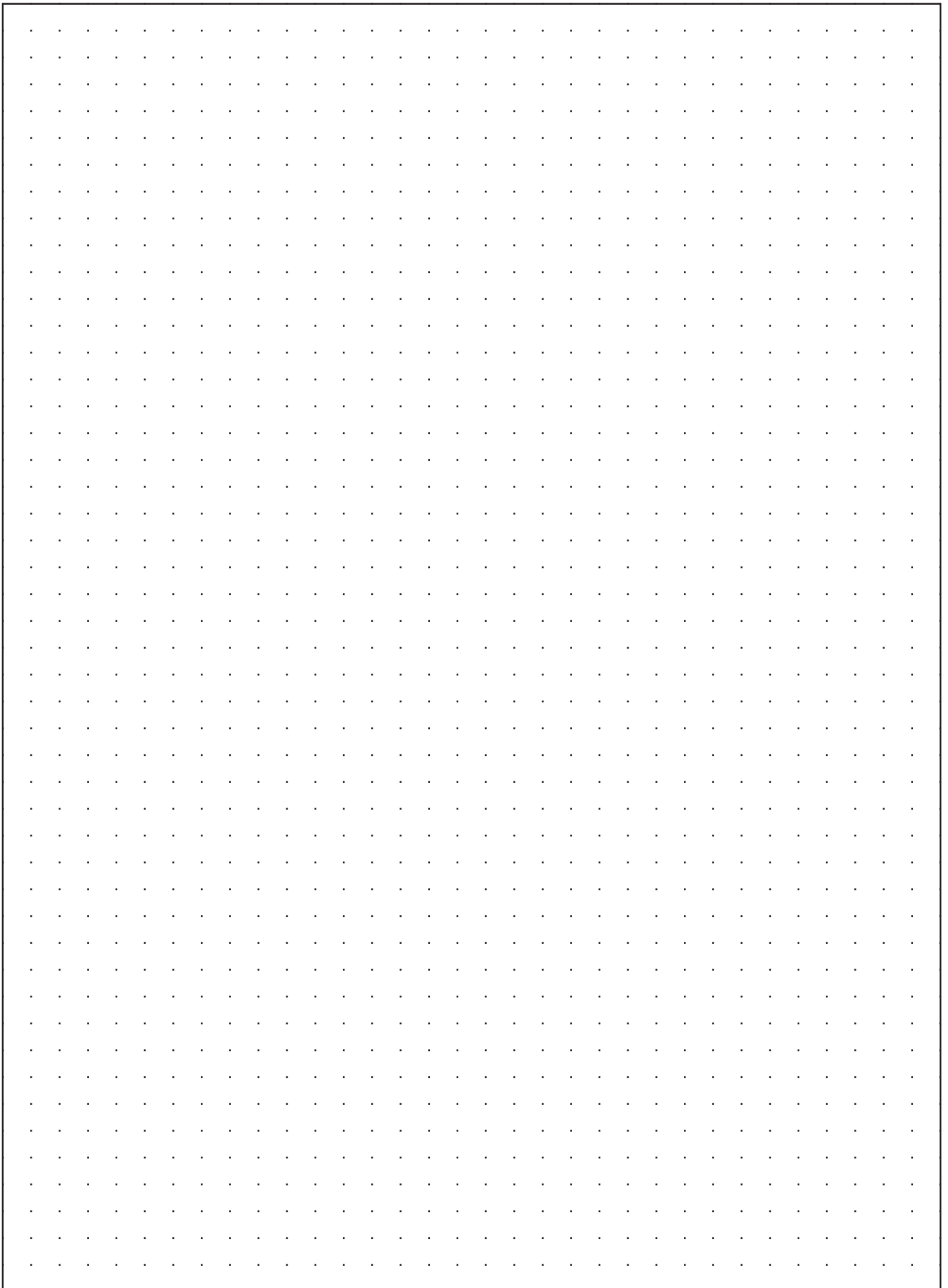
A large rectangular area filled with a grid of small dots, intended for taking notes. The dots are arranged in a regular pattern, forming a grid that covers most of the page's content area.

Notes

A large rectangular area filled with a grid of small dots, intended for taking notes. The grid consists of approximately 25 columns and 35 rows of dots, providing a structured space for writing.



Design



Motors



Manufacture



Design



Gearboxes



Service



eShop



VSD's



Specialist



Gearboxes



Motors



Shop

WESTERN CAPE

Unit 15, Santos Park,
Cnr of La Belle & Cilmor Rd
Cape Town
+27 21 949 6862
+27 78 365 6949

SOUTHERN CAPE

13B Pioneer Rd
George
+27 44 878 0349
+27 78 423 8962

KWAZULU - NATAL

Unit 7, Acacia Park, 1 Falcon Road
Imbonini Park, Shaka's Head
+27 81 479 4880

ZAMBIA

2 Pollak Street
Kitwe
+260 966 509132
+260 977 280479



Distribution



Manufacture



Service



Specialist



eShop



VSD's



Design



Pumps



Distribution



Specialist



VSD's



Shop



Gearboxes

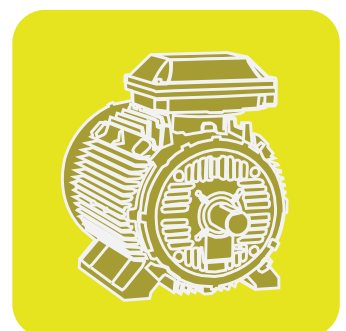

Motors